Introduction

Scope and purpose of the manual

This User Manual explains how to install and operate the RSU 8 fusion splicer. The primary aim of this manual is to make the user as familiar with the splicer as possible.

Basic maintenance procedures are also described to enable the user to keep the RSU 8 in excellent working condition.

Important!

Ericsson requires all users to read this manual before operating the RSU 8 splicer.

The reader

Inexperienced users will learn how to carry out basic splicing with the RSU 8 as described in Chapter 2 "Basic operation".

However, users who are more advanced will be able to extend their knowledge by learning how to change parameters, implement utilities etc.

Once the main routines and procedures have been learned, the user can use the Quick Reference Guide as a fast reminder of how to use the RSU 8.

Software

This manual is valid for the following software revisions:

77PR002 R2

77PR001 R2

Introduction to the RSU 8

The RSU 8 fusion splicer is compact, portable and ergonomically designed. The splicer can mass splice up to 8 optical fibres or even single fibres in both field and stationary operational situations.

The splicing programs available with the RSU 8 cover the most common types of ribbon and single fibre. However, it is possible to define splicing programs to meet any special single or ribbon fibre requirement.



Applications

The RSU 8 is designed for permanent low-loss splicing of single-mode, multimode and dispersion-shifted silica fibres used in telecom and data applications.

The RSU 8 employs fixed V-groove alignment technology making it possible to splice single fibres as well as ribbon with up to 8 fibres. The process is fully automatic and the splice loss for each fibre is estimated quickly and accurately.

The splicer has a built-in heat oven for applying heat-shrinkable tubes to protect the splice. As an option, the splicer can be fitted with a proof tester.

Chapter 1 - Installation

This chapter contains the following basic information:

- *Safety and precautions*
 - *operational safety precautions*
 - *maintenance precautions*
 - *transport and storage precautions*
- *Installation upon delivery*
 - *unpacking the splicer*
 - *removing the cover*
 - *unlocking the safety shield*
- *RSU 8 splicer kit*
- *Overview of external parts*
 - *external part description*

Safety and precautions

As the RSU 8 is designed for fusion splicing silica glass optical fibers **it is very important that it is not used for any other purpose.**

The splicer is a precision instrument and must be handled with care. Therefore, the following safety rules and general precautions regarding the use and handling of the RSU 8 **must be observed by the user at all times.**



Operational safety precautions

1. **Do not use** the splicer in places where there is a risk of explosion.
2. **Never touch** the electrodes when the splicer is switched on.
3. **Never open** the splicer or the power supply.

Maintenance precautions

1. Never use hard objects to clean the V-grooves and electrodes.
2. Never use acetone for cleaning any part of the splicer.
3. Always follow the maintenance instructions in this manual.

Transport and storage precautions

1. Put the cover on the splicer when it is not in operation (fig. 2 pg. 4).
2. Keep the splicer clean and dry.
3. Always keep the splicer in its portable case when not in use.
4. Always transport the splicer in its portable case to protect it from damage and dirt.
5. Lock the safety shield during transport (fig 6 pg. 6).
6. Never leave the splicer either in direct sunlight or in a place exposed to excessive heat.
7. Keep the humidity to a minimum where the splicer is stored. The humidity must not exceed 98%.

Installation upon delivery

By the time the user opens the User Manual, the following instructions will have been followed (they are printed on a yellow paper ① found inside the portable case).

Unpacking the splicer

1. Unpack the splicer by lifting it upwards from the back as illustrated.

However, they are repeated in this chapter for information should the splicer need to be transported to another location in the future.

Important!

Follow these instructions carefully.

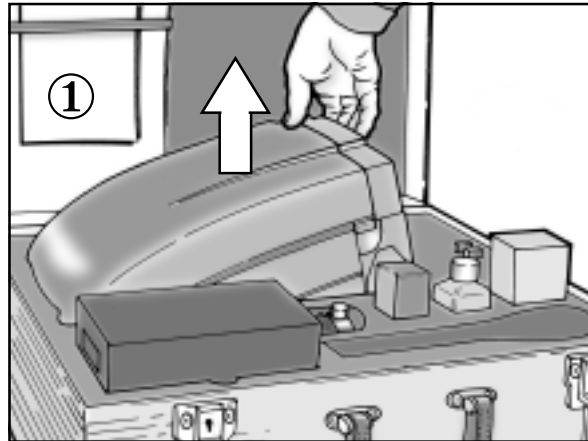

Fig. 1 - Unpacking the splicer

Removing the cover

1. Pull out the two tabs ① at the rear of the cover.
2. Lift the cover ② about 3 cm (1 in.) and slide it towards the front of the splicer ③.

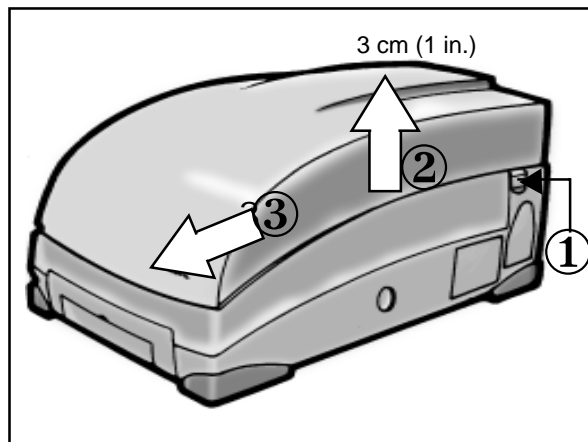

Fig. 2 - Removing the cover

Unlocking the safety shield

1. Pull out the safety shield lock ① before opening the safety shield ②.

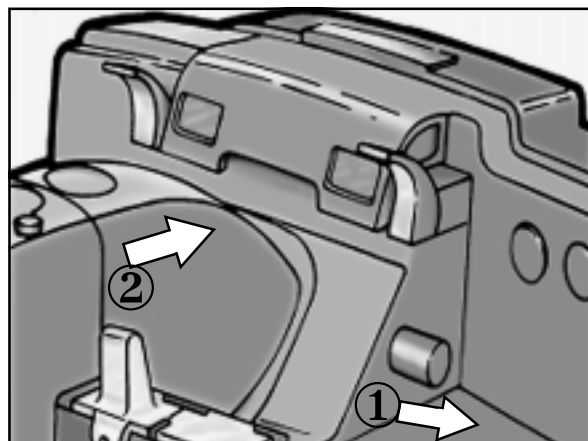

Fig. 3 - Unlocking the safety shield

RSU 8 splicer kit

On delivery the RSU 8 fusion splicer arrives in a portable case together with the following items:

Code	Item	Qty
a	RSU 8 fusion splicer	1
b	covering lid	1
c	portable case	1
d	spare electrode set	1
e	fibre holders for 8-fibre ribbon	2
	tool set:	
f	- electrode brush	1
g	- screwdriver	1
h	- brush for V-grooves	1
i	- electrode tweezers	1
	user documentation (not shown here)	1

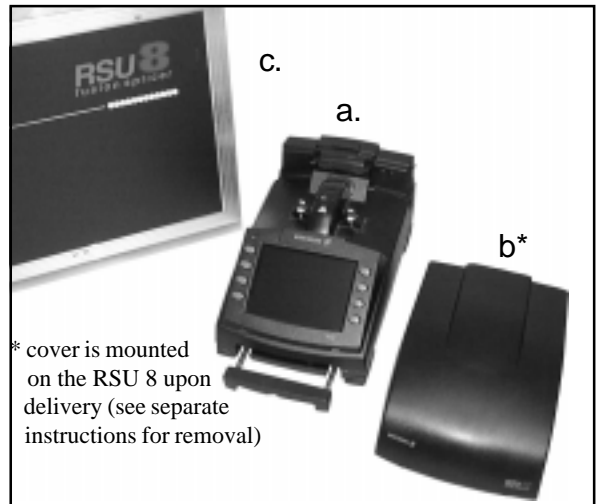

Fig. 4 - Splicer, cover and portable case

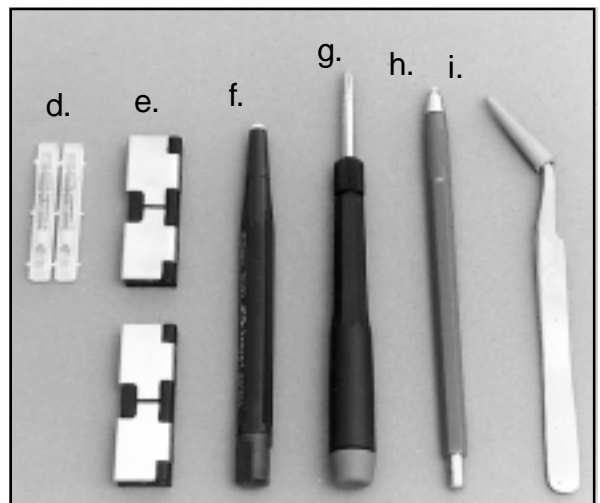

Fig. 5 - Tool set accompanying the splicer

Overview of external parts

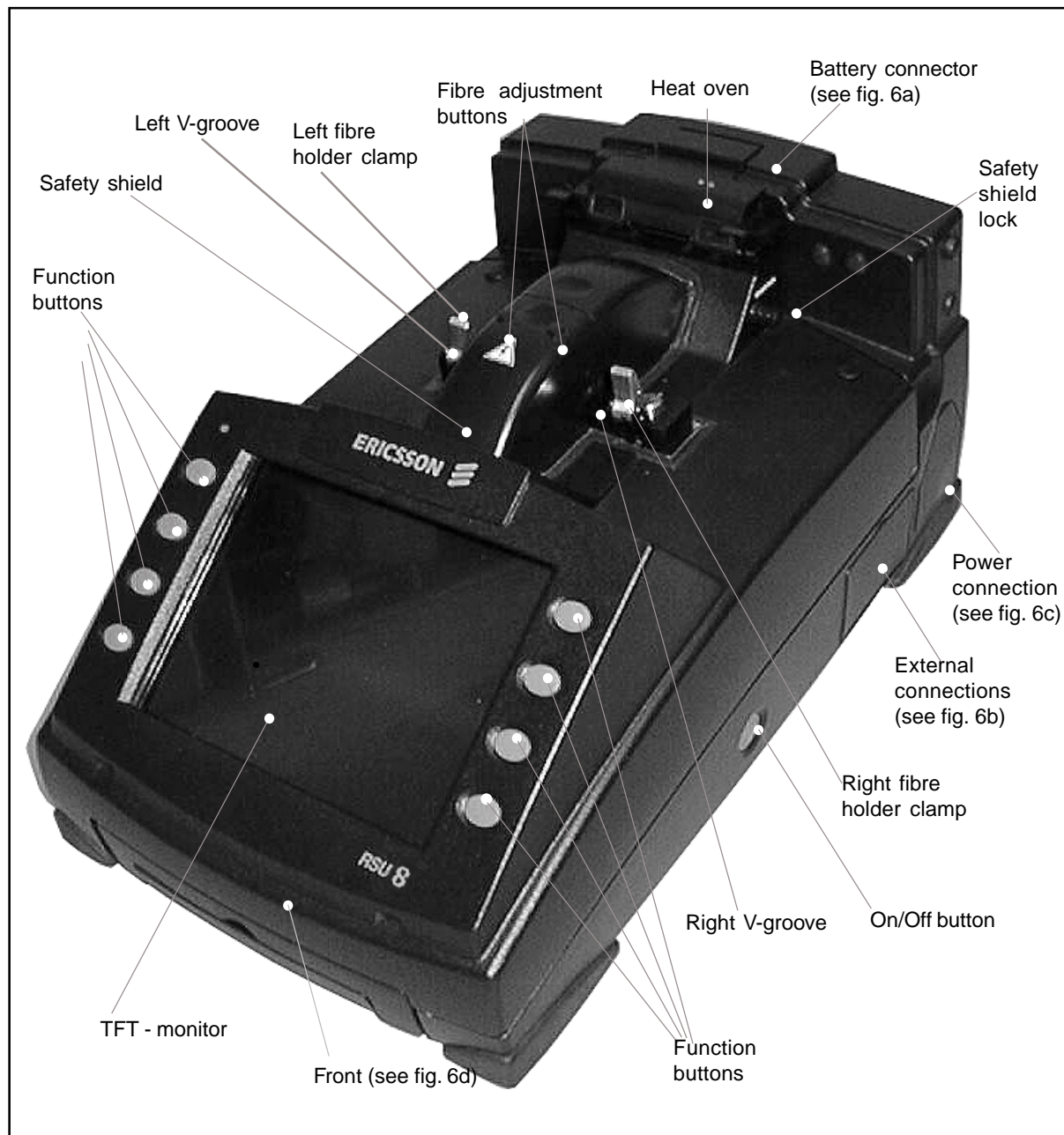

Fig. 6 - Total overview of external parts

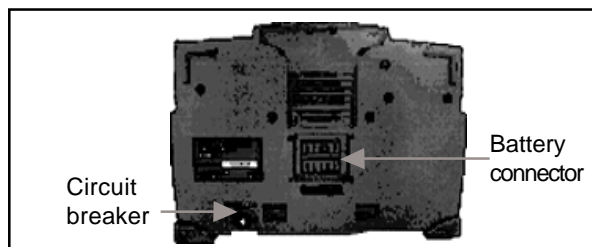

Fig. 6a - Battery connector (rear view of splicer)



Fig. 6b - External connections

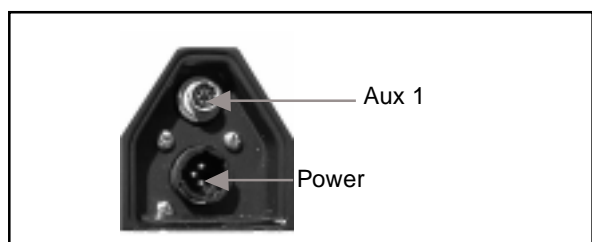

Fig. 6c - Power connection

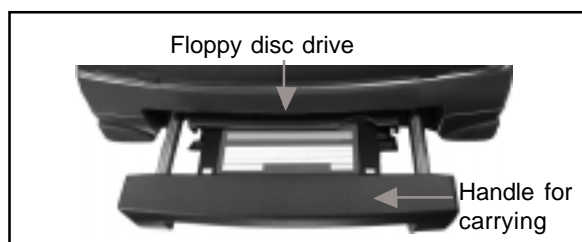

Fig. 6d - Front

Part description

Part	Description
Fibre adjustment buttons	Adjust position of fibres in the V-grooves.
Heat oven	Protects the splice with a heat-shrink tube.
Battery inlet	Connects battery to the splicer.
Power connection	Connects external power supply to the splicer.
External outlets	<ul style="list-style-type: none">- 12V output- external VGA- serial communication port
Right/left fibre holder clamp	Holds the left and right fibre holders in position.
Function buttons	Used to select functions via the icons displayed on the monitor.
Safety shield	Protects the electrodes and V-grooves (closed when splicer is not in use).
Safety shield lock	Locks the safety shield in position during transport.

Chapter 2 - Basic operation

This chapter contains the following information:

- *How to start the splicer*
- *How to prepare the fibres*
 - *how to strip the fibres*
 - *how to clean the fibres*
 - *how to cleave the fibres*
- *How to position fibres in the V-grooves*
- *How to carry out the auto-splicing process*
- *Testing the strength of the spliced fibres*
- *How to protect the splice*
- *Reference notes*
 - *"Pause before fusion"*
 - *"Show all est. losses"*

How to start the splicer

If you have followed the instructions in chapter 1 para. "Installation upon delivery" then the RSU 8 splicer can be started.

1. Connect the power supply to the splicer.
 - Note 1:**
Screw the power connector into the outlet in a clockwise direction.
 - Note 2:**
An external VGA display monitor can be connected via the monitor outlet on the splicer.



Fig. 7 - Connecting the power supply to the splicer

2. Connect the stripper to the splicer.
 - Note:**
Simultaneously push and turn the stripper connector into either the AUX1 or AUX2 outlet.



Fig. 8 - Connecting the stripper to the splicer

3. Connect the ultrasonic cleaner to the splicer.

Note:

Simultaneously push and turn the ultrasonic cleaner's connector into either the AUX1 or AUX2 outlet.



Fig. 9 - Connecting ultrasonic cleaner

4. Turn on the splicer.

Note:

Press down the On/Off button until the green LED on the top left of the front panel is lit.

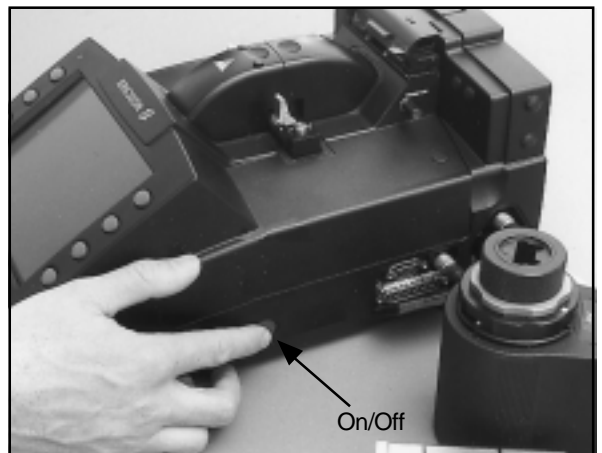

Fig. 10 - Turning on the splicer

5. Clean the V-grooves if necessary (see Chapter 6 "Maintenance").
6. Clean the electrodes if necessary (see Chapter 6 "Maintenance").

How to prepare the fibres

There are 3 basic preparatory steps to be completed before the fibres can be put in the splicer:

- stripping
- cleaning
- cleaving

Important!

Preparing the fibres for splicing is one of the most important factors in the splicing process and must be carried out with the utmost care to minimise splice losses.

Poorly cleaned and cleaved fibres will normally result in high splice loss and low mechanical strength.

How to strip the fibres

1. Place a heat-shrinkable protection sleeve onto one of the ribbons before stripping the fibre .



Fig. 11 - Protection sleeve placed on the ribbon

2. Put the ribbons into the left and right fibre holders so that between 25-35 mm of ribbon sticks out as illustrated in fig. 12.

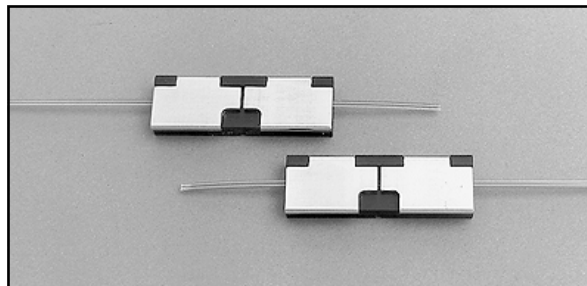

Fig. 12 - Ribbons placed in the left and right fibre holders

3. Remove the coating with the stripping tool (according to your own stripping tool instructions).

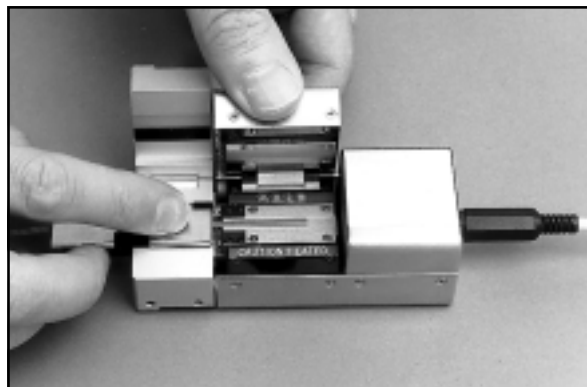

Fig. 13 - Coating removed with stripper

How to clean the fibres

1. Insert the fibre holder containing the stripped fibres into the fibre holder unit of the ultrasonic cleaner.

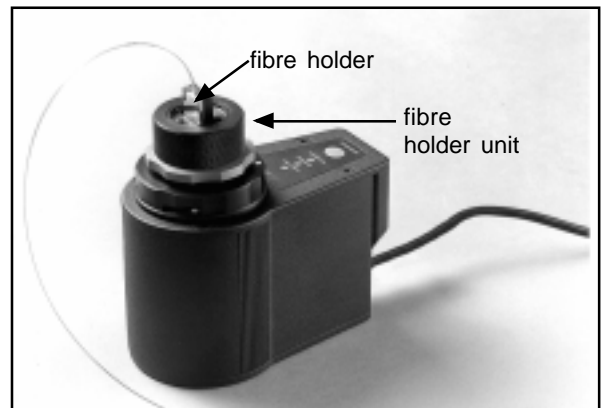

Fig. 14 - Inserting fibre holder into the cleaner

2. Press the "Start/Stop" button on the control panel to start the cleaning process.

Note:

The "Process" LED flashes with a yellow light.

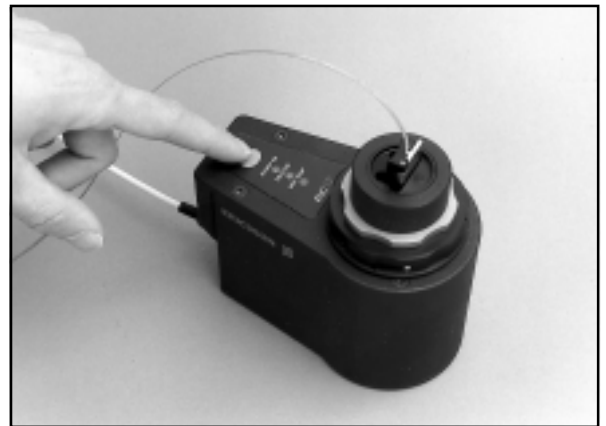

Fig. 15 - Pressing "Start/Stop" button

3. After the cleaning process (lasting 10 seconds), is completed the "Process" LED stops flashing and shines with a continuous yellow light and a signal is heard.

4. Remove the fibre holder **before** the ultrasonic cleaner is turned off.

Note:

More details of the ultrasonic cleaner can be found in the User's Instruction Ultrasonic Cleaner EUC 12.

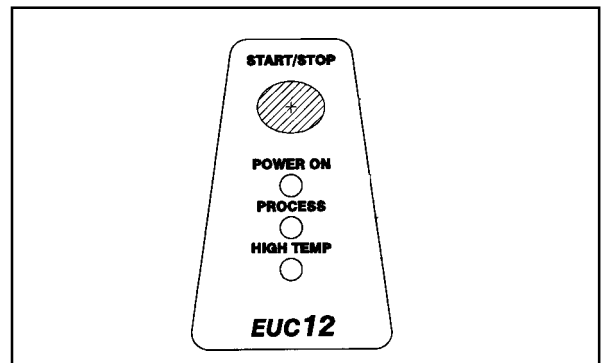

Fig. 16 - Schematic of the control panel

How to cleave the fibres

1. Lift the clamp.
2. Place the fibre holder containing the stripped and cleaned fibres onto the cleaver.
Note:
When placing the fibre holder onto the cleaver, press it simultaneously forwards and towards the top left.
3. Close the clamp.

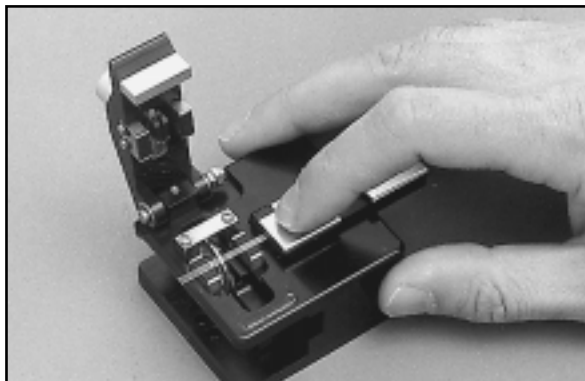

Fig. 17 - Placing fibre holder onto the cleaver

4. Move the diamond blade to the back of the cleaver.
Note:
Whilst moving the blade keep the fibre holder pressed forwards and towards the left.

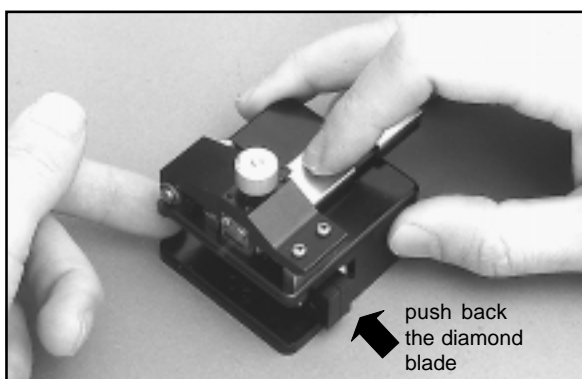

Fig. 18 - Moving the diamond blade backwards

5. Press down the button on top of the clamp.
Note:
By doing this the fibres bend and are broken off.
6. Raise the clamp.

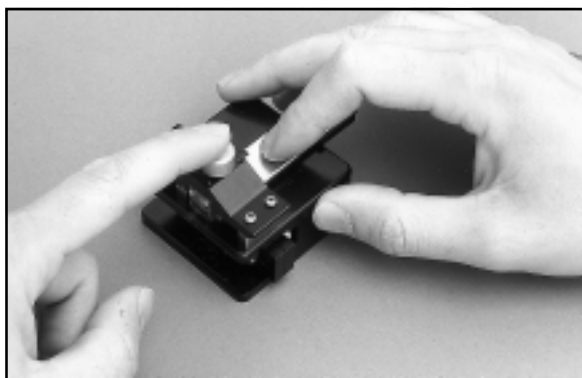

Fig. 19 - Pressing down the button

7. Lift the fibre holder with the cleaved fibres straight up and out of the cleaver.
8. Remove the remains of the cleaved fibres from the cleaver with a piece of adhesive tape.
Note:
Be careful not to touch the diamond blade with the tape or anything else.

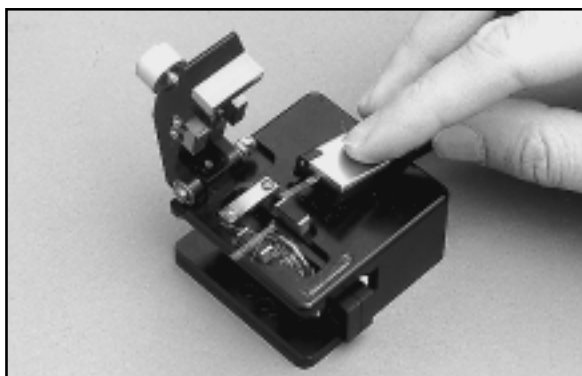

Fig. 20 - Lifting away the fibre holder from the cleaver

How to position fibres correctly in the V-grooves

1. Open the safety shield.
Note:
Ensure the safety shield lock is pulled out (i.e. in the released position).

2. Raise the fibre clamp and fibre holder clamps.
Note:
Clean the V-grooves if they are dirty.

3. Place the fibre holders containing the fibres in the splicer.
Note:

You can see whether the fibres are positioned in the V-grooves from the images on the monitor. If they are not, then adjust the fibres by slightly moving the fibre holders from side to side.

4. Close the fibre clamp.
Note:

It is important that the fibre clamp is closed before closing the fibre holder clamps.

5. Close the fibre holder clamps.

6. Close the safety shield.
Note:

Alternatively, you can first close the safety shield (the fibre clamp closes automatically) and then the fibre holder clamps.

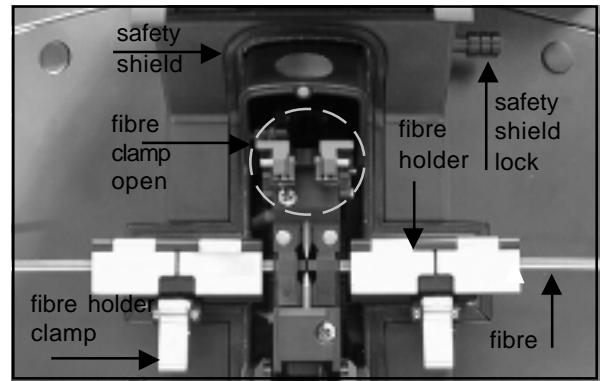

Fig. 21 - Fibre holders with fibres placed in the splicer

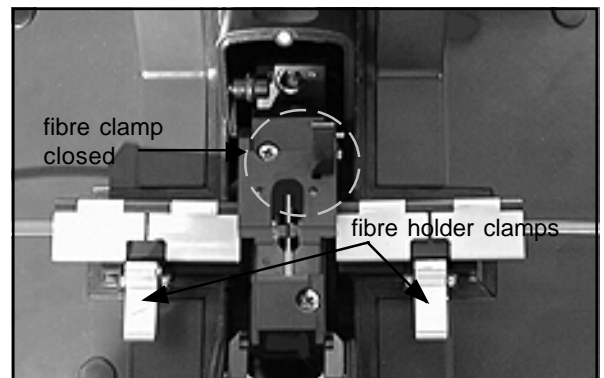

Fig. 22 - Fibre clamp and fibre holder clamps closed

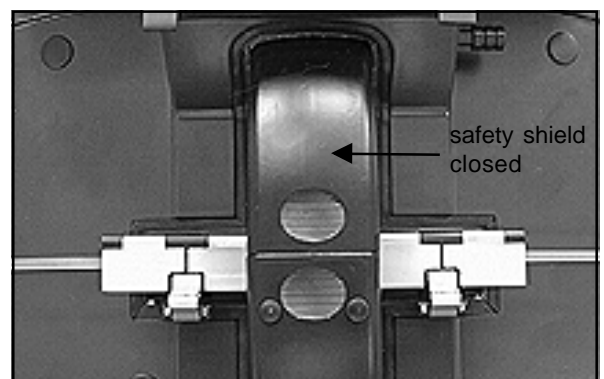

Fig. 23 - Safety shield closed

Examples of fibre problems

Upon inspection, there may be either dust remaining on the fibres or the fibres themselves may be broken (see fig. 24).

If too much dust remains on the fibres or they are broken, then prepare the fibres again.

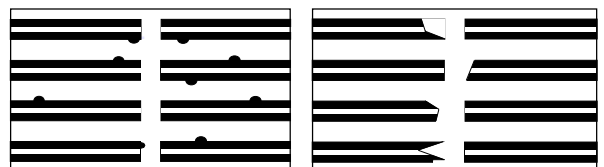

Fig. 24 - Dust on the fibres and broken fibres

How to carry out the auto splicing process

1. Choose the correct splicing program (see Chapter 4 "The Set up menu").
2. Press SPLICE (now refer to fig. 25).
Note:
For a full understanding of the auto splicing process read the Reference Notes about "Pause before fusion" and "Show all est. losses" at the end of this chapter and act as necessary.
3. If necessary check the geometry of the fibres.
4. To complete the splicing process, press: RESUME, or
5. If the radial misalignment (i.e. cladding offset), cleave angle or cleave length difference of any fibres is too great, press: ABORT SPLICE
6. When splicing is complete check the estimated loss and the hot images (see Chapter 3 "Evaluating the splice").
7. Open the safety shield.
" the fibre clamp.
" the fibre holder lids and remove the fibres.
(see pg. 15 "How to protect the splice").
8. Press RESET to reset the splicer ready for the next splice.

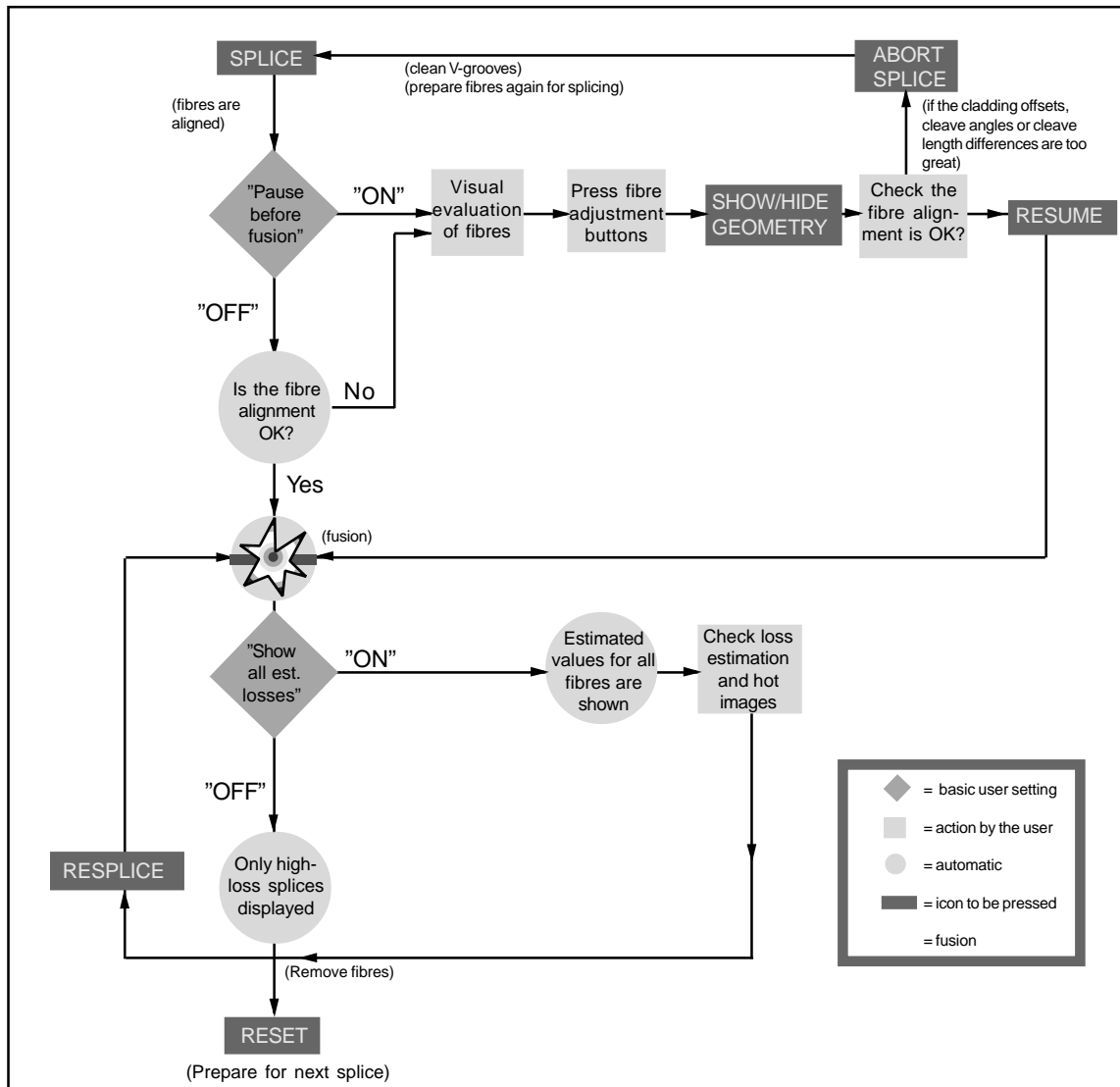

Fig. 25 - Schematic of the auto splicing process

Testing the strength of the spliced fibres (an optional function)

If desired, the strength of the fibres can be tested using an optional pre-mounted proof tester.

See Appendix C for details of this function.

How to protect the splice

After splicing, protect the joint by using a heat-shrink sleeve and the heat oven which is mounted on top of the splicer.

Before shrinking the sleeve, check whether the proper shrinking program has been selected (*see Chapter 4 "Set up menu"*).

1. Open the heat oven lid and both ribbon clamps .

Note:

The heat oven lid can only be opened to a maximum angle of 45°. Do not try to force it open further.

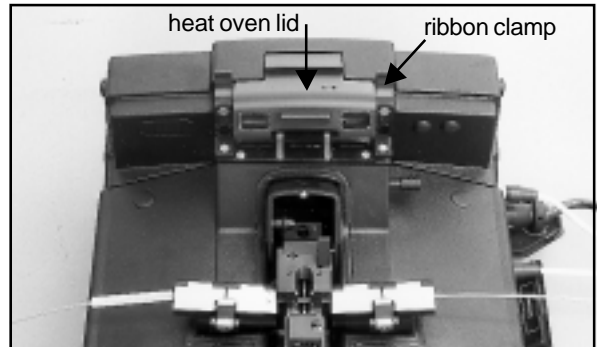

Fig. 26 - Opening heat oven lid and ribbon clamps

2. Open three of the four fibre holder lids as shown in fig 27.

3. Centre the heat-shrink sleeve over the splice point, stretching the ribbon at the same time.

Note:

Position the heat-shrink sleeve so that the glue is uppermost and will make contact with the heat oven's hot plate.

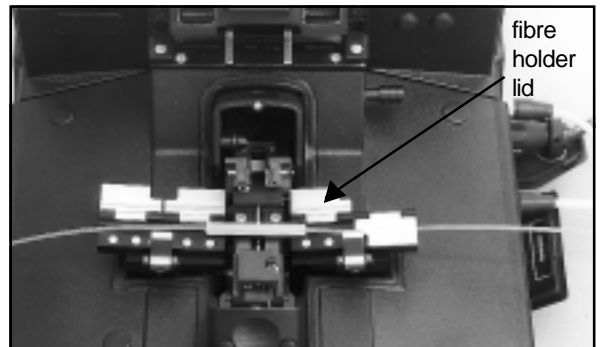

Fig. 27 - Centering sleeve over splice point

4. Open the fourth fibre holder lid and carefully move the ribbon from the splicer to the heat oven.

Important!

Do not bend either the splice point or the fibres when transferring them over to the heat oven. If necessary, centre the heat-shrink sleeve again.



Fig. 28 - Moving ribbon from splicer to heat oven

5. Carefully slide the ribbon back so that the ribbon clamps close automatically.

Important!

Hold the ribbon stretched before the clamps close.

6. Close the heat oven lid.
7. Select the correct shrinking program and return to the Main menu (*see Chapter 4 "The Set up menu"*).

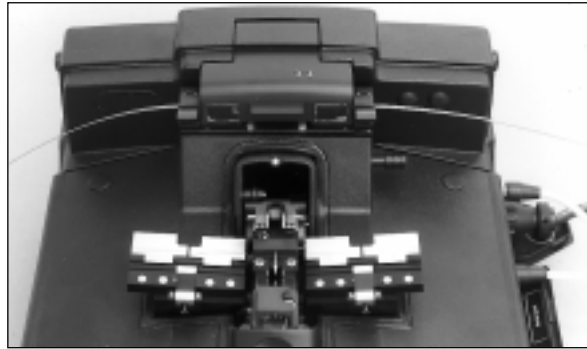

Fig. 29 - Closed heat oven lid

8. From the Main menu press SHRINK.

Note 1:

The yellow lamp on the oven shines continuously during the shrinking process and flashes during the cooling process.

Note 2:

When the shrinking process is complete, the fan stops and a signal is heard.

Note 3:

If the ABORT SHRINK button is pressed, the shrinking process stops and the fan starts immediately. The fan runs until the oven has cooled down or the ABORT SHRINK button is pressed again.



Fig. 30 - Activating the shrinking process

9. Open the heat oven lid and the ribbon clamps when the shrinking process is complete.

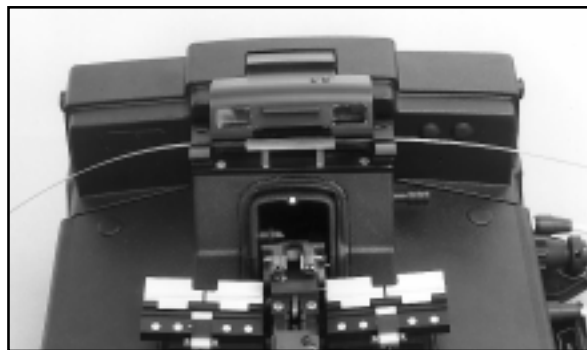

Fig. 31 - The heat oven lid is opened first

10. Remove the ribbon.

Note:

The entire shrinking process takes between 1,5 to 2 min depending on the shrink program used.

Reference notes

"Pause before fusion" setting - "On"

If the "Pause before fusion" setting (one of the basic user parameters) is set to "On" (see Chapter 4 "The Set up menu" and fig. 25a), then the splicing process **always** halts before fusion. The user can visually evaluate the fibre alignment and geometry (see fig. 32) from both views as follows:

1. To calculate the radial misalignment (cladding offset), cleave angles and fibre gaps press:

SHOW GEOMETRY

Note 1:

The **cladding offsets** appear first on the monitor. Press NEXT QUANTITY to show **cleave angles** and then press once again to show **fibre gaps**.

Note 2:

The calculated values are displayed in red if they exceed the following limits in the current splice program:

- **Cladding Offset Limit** (maximum allowed radial misalignment for fibre pairs in μm).
- **Cleave Angle Limit** (maximum allowed cleave angle in degrees).
- **Cleave Length Difference Limit** (maximum allowed difference in gap between fibre pairs in μm).

2. Press CHANGE VIEW to see the fibres from the other camera view.

Note:

You can alternate between views as many times as necessary.

"Pause before fusion" setting - "Off"

If this setting is "Off" then the splicing process halts before fusion if the cladding offset, cleave angle or gap difference for any fibre or fibre pairs is greater than the limits set in the current splice program (see Note 2 above). Otherwise the splice is carried out automatically.

The calculated values for these geometrical quantities are also displayed on the monitor as described previously, and appear in red if they exceed the limits in the current splice program. Proceed according to steps 3 to 6.

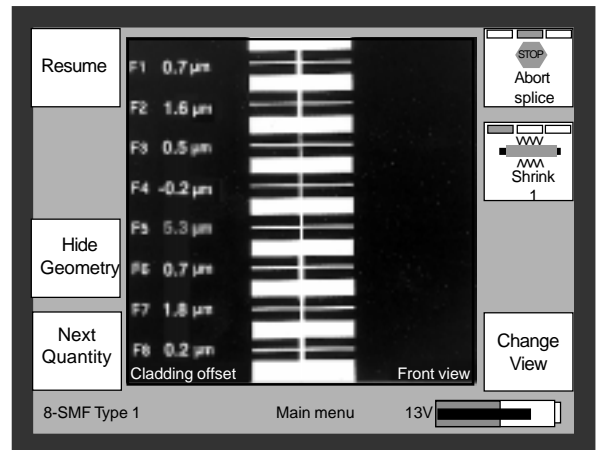

Fig. 32 - Display showing radial misalignment when "Pause before fusion" setting is "On"

3. If there are any offsets, press the fibre adjustment buttons on top of the safety shield to adjust the fibres.
4. To remove the values from the monitor press:

HIDE GEOMETRY

5. To make a new calculation press:

SHOW GEOMETRY

6. To complete the splicing process press:

RESUME

Note:

If the values are too great then press ABORT SPLICE. Clean the V-grooves and/or prepare the fibres again.

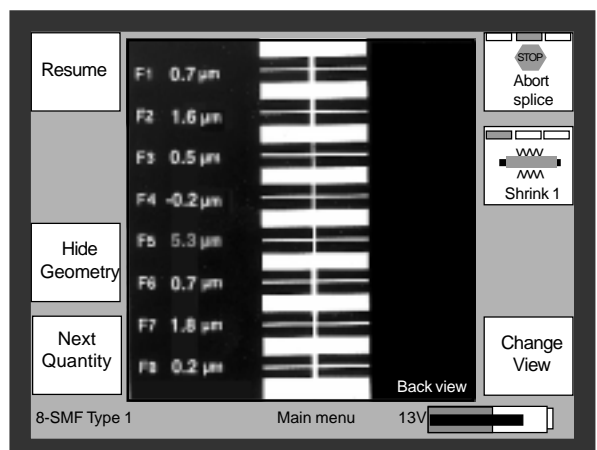
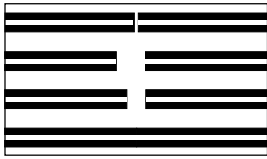

Fig. 33 - Example of display when the "Pause before fusion" setting is "OFF"

Reference notes *cont.....*

"Pause before fusion" *cont.....*

Examples of problems that can cause the splice process to halt before fusion



*Uneven cleave length
(prepare fibres again)*

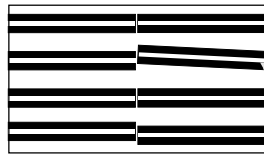

*Offset too great
(clean V-grooves and/or
prepare fibres again)*

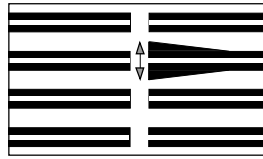

*Fibre movement during
alignment
(clean V-grooves and
prepare fibres again)*

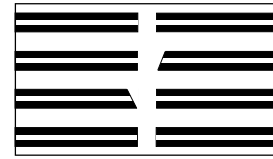

*Bad cleave angle
(strip and cleave
fibres again)*

"Show all estimated losses" setting - "ON"

If this setting (one of the basic user parameters) is "On" (see Chapter 4 "The Set up Menu" pg. 38) then the estimated values for all fibres are displayed on the monitor (fig. 34). The user should:

1. Visually evaluate the hot images.
2. Re-splice if necessary.
3. Remove the fibres.
4. Press RESET to reset the splicer for the next splice.

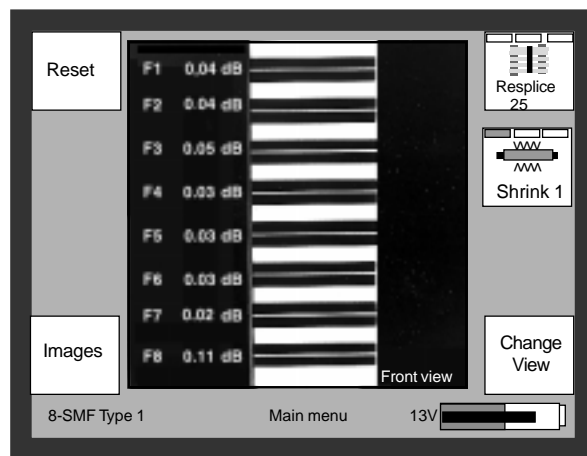

Fig. 34 - Total estimated values for all the fibres

"Show all estimated losses" - "Off"

If this setting is "Off", then the estimation values are not displayed. However, if the estimation values exceed the limits defined in the splice program (i.e. "Min. shown est. loss" setting), then these values are shown in red on the monitor.

Note:

If the advanced splicing parameter "Estimation method" (see Chapter 4 "Set up menu") is defined as "Cladding" then no hot image estimation values are displayed as the splicer only evaluates Pre-splice and Overlap images (i.e. cold images).

Chapter 3 - Evaluating the splice

This chapter contains the following information:

- *Images*
 - *general*
 - *type of images*
 - *displaying the stored images*
 - *order of the stored images*
 - *how to see the evaluated information from the stored images*
 - *how to check the fusion current...*
- *Reference notes*

Images

General

There are two cameras mounted inside the splicer; one at the back and one at the front. During the splicing process these two cameras take a total of 12 images which are saved in the memory (fig. 35).

These images show the fibres before, during and after the fusion process and enable the splicer to estimate the splice loss. However, the user can also recall each of these images when the splice process is completed.

Type of images

There are two types of images produced within the RSU; cold and hot images. The hot images show the fibres during splicing when the arc is on and the cold images show the fibre before and after fusion.

heated fibres during fusion. Hot image 2 and Hot image 3 are taken with low and high camera exposures respectively.

The hot images are produced when the cameras image the thermal radiation of the

Because the fibre cores contain dopants, they emit more light when subjected to high temperatures which means that they can be seen in the hot images.

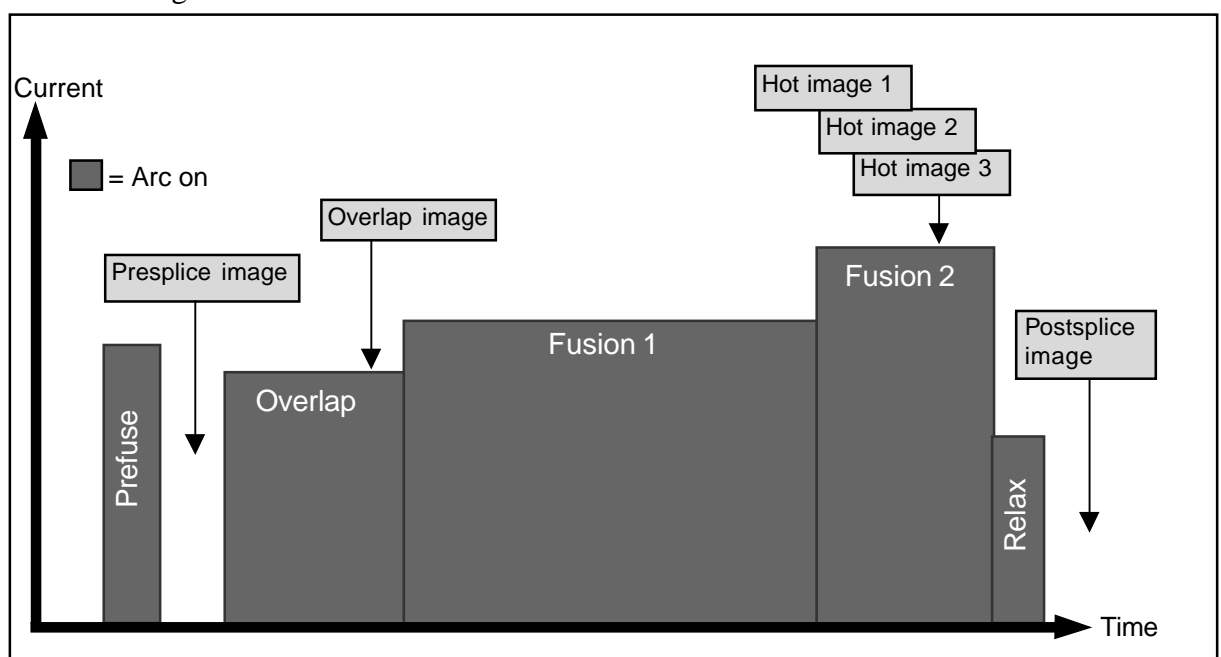

Fig. 35 - Image sequence overview

Displaying the stored images

All stored hot and cold images taken during a splice can be displayed immediately after the fusion is complete. However, they can also be displayed later by running the application "Images from last splice" available under the Utilities menu (see Chapter 5 "The Utilities menu").

Order of the stored images

The figure below illustrates the order in which the images are stored.

The first image shown on the monitor is the cold Postsplice image. However, every image can be studied and compared as many times as necessary by pressing either PREVIOUS or NEXT.

To change views between back and front camera view press CHANGE VIEW.

To magnify the view of the image on the monitor, press ZOOM.

Note:

The image can then be scrolled up and down by pressing PREVIOUS or NEXT.

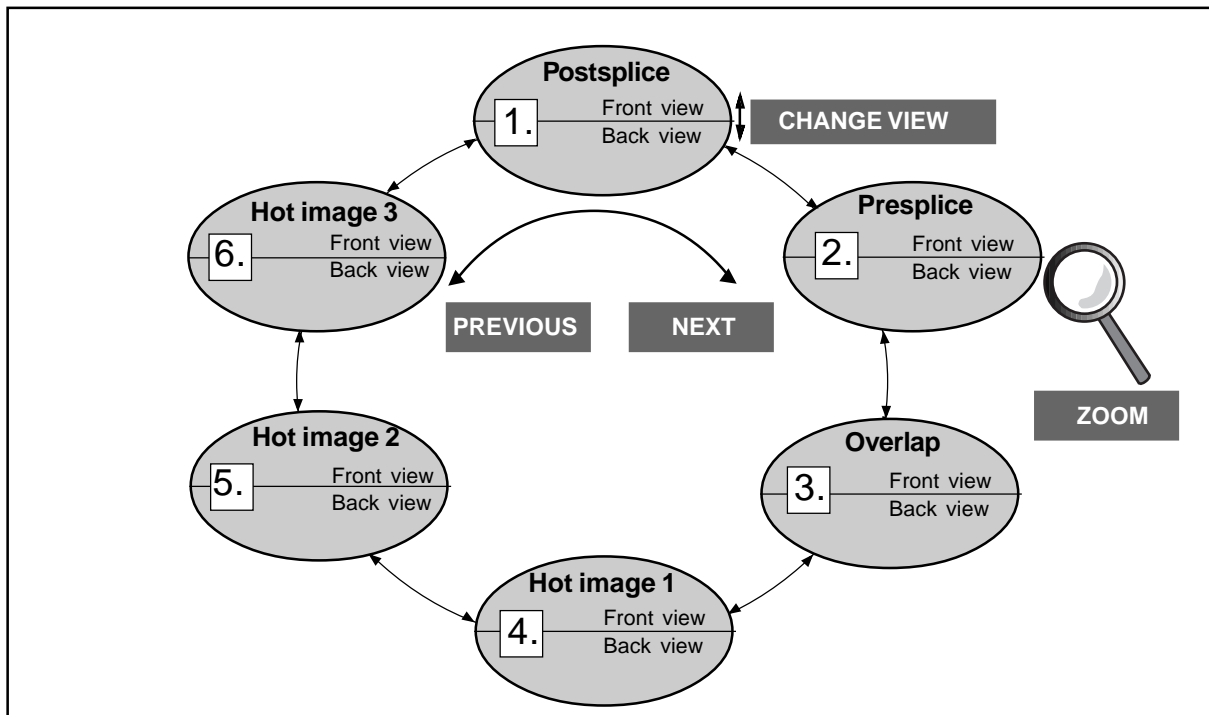

Fig. 36 - Overview of stored images

How to see the evaluated information from the stored images

Information about the loss estimation can be seen either by pressing the INFO button or via the Utilities menu "Images from last splice" (see Chapter 4). The hot or cold images are displayed on the monitor, as follows:

1. Presplice (cold image)

Information about fibre geometry and alignment is displayed as follows:

- col. 1 - left fibre diameter (pixels)
- col. 2 - left cleave angle (deg.)
- col. 3 - cladding offset (microns)
- col. 4 - fibre no.
- col. 5 - gap between fibres (microns)
- col. 6 - right cleave angle (deg.)
- col. 7 - right fibre diameter (pixels)

2. Overlap (cold image)

Similar information as in the Presplice image is displayed. The only difference now is that the fibres are overlapped.

3. Hot images 1, 2 and 3

Loss estimation based on fibre geometry and fibre core deformation after fusion is performed. The estimated values for the current image are displayed on the left of the hot fibres.

The curves on the right show the magnified shape of the fibre cores in the Critical Splice Area (CSA).

4. Postsplice (cold image)

Displays the total loss estimation data for all fibres when the splice is completed.

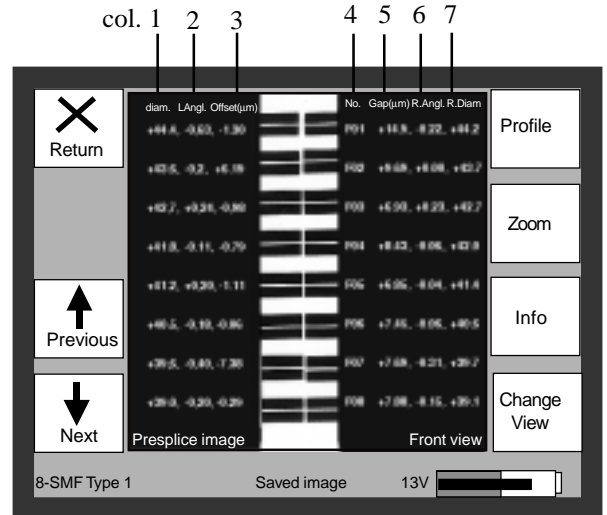

Fig.37 - Measurement data etc. (in cold image)

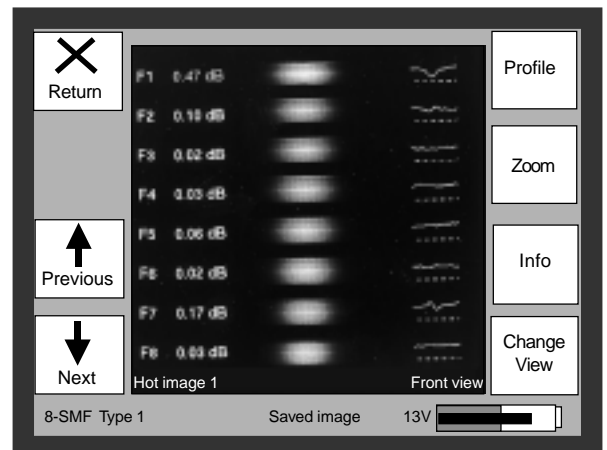

Fig. 38 - Example of estimated loss values for Hot Image 1

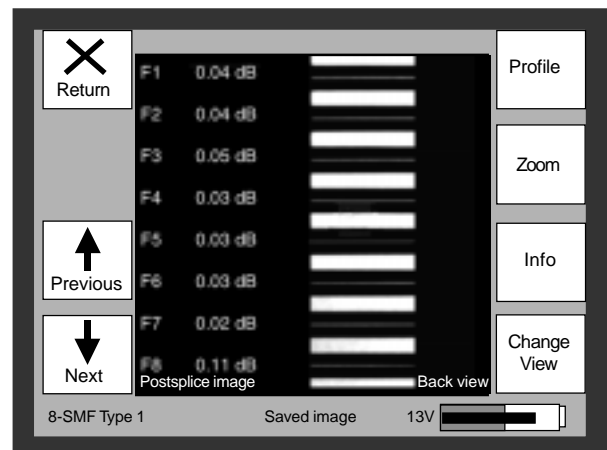

Fig. 39 - Example of Postsplice image showing total estimated loss values for all fibres

How to check the fusion current (temperature) by displaying the light intensity profile of a stored image

It is possible to study the light intensity profiles of each fibre’s thermal radiation by pressing the PROFILE button.

The user can see the estimated fusion heat by looking at the light intensity profile of **Hot Image 1**.

Example of correct fusion heat

If the profiles of Hot Image 1 are, on average, between 100 and 200 gray scales of the image, then the fusion heat is correct (fig. 40).

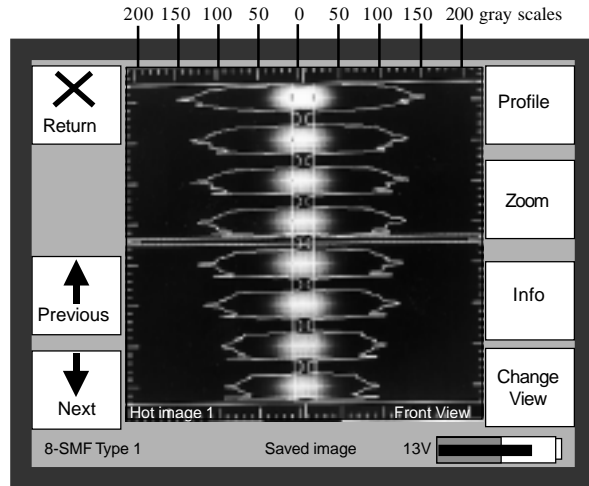

Fig. 40 - Example of light intensity profiles when the fusion heat is correct

Example of too low fusion heat

If the profiles of Hot Image 1 are, on average, less than 100 gray scales, then the fusion temperature is too low and the fusion currents must be increased (fig. 41).

Note:

Run the Auto Current adjustment function under the Utilities menu to adjust fusion currents automatically (see Chapter 5 "The Utilities menu").

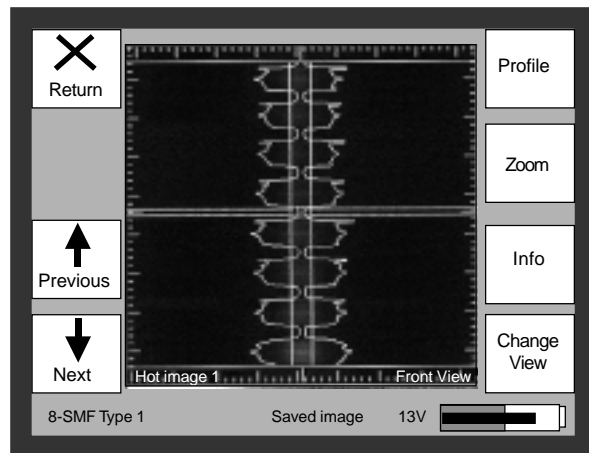

Fig. 41 - Fusion heat is too low

Example of too high fusion heat

If the profiles of Hot Image 1 are, on average, more than 200 gray scales, then the fusion temperature is too high and the fusion currents must be reduced (fig. 42).

Note:

Run the Auto Current adjustment function under the Utilities menu to adjust fusion currents automatically (see Chapter 5 "The Utilities menu").

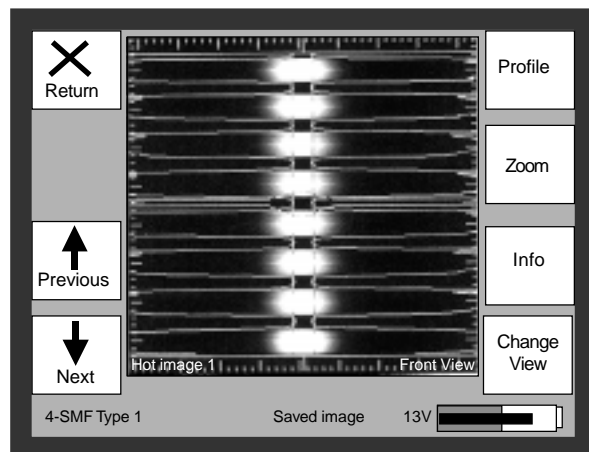

Fig. 42 - Fusion heat is too high

Reference notes

Examples and analysis of different problems detected when evaluating the hot images

Illustrated below are a number of typical splicing problems that are found within the Critical Splice Area (CSA). These problems can be studied by evaluating the stored hot images.

Example A: Is the core straight?

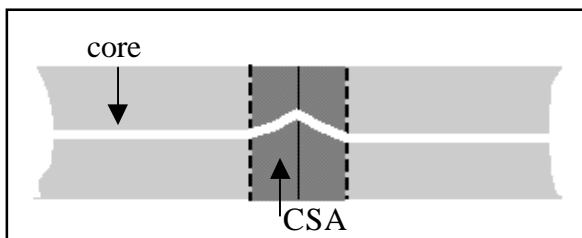

Is the core (i.e. the bright line in the middle of the fibre) straight within the CSA? A bent core is often caused by a bad cleave resulting in a large cleave angle.

Result: Additional splice loss.

Example B: Is there an offset?

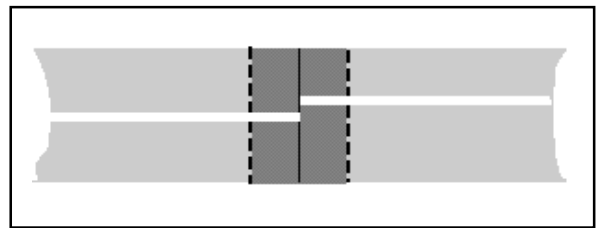

A core offset can be caused by splicing fibres with a large core eccentricity.

Result: Additional splice loss.

Example C: Are there any hot spots?

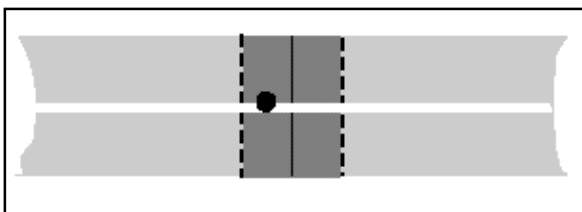

Are there any bright ("hot") spots on the fibre? These can be caused by dirt on the fibre, a badly cleaved fibre end or an air bubble trapped inside the fibre.

Result: Possible reduced splice strength and, if located in the core, additional splice loss.

Note:

If the core of the splice is straight, and there are no offsets, "hot" spots or white lines, then the splice is probably a good quality one.

Example D: Is there a white vertical line between the fibres?

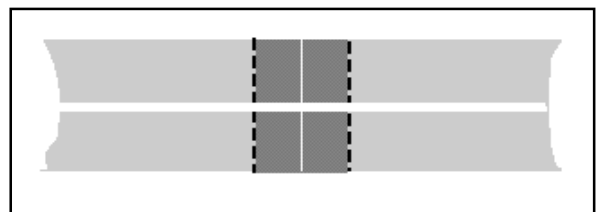

A white vertical line between the two fibres may appear if the end faces of the fibres are dirty. This can be caused by cleaning with a contaminated solvent, a poorly cleaved fibre or a too low fusion current.

Result: Possible additional splice loss and reduced splice strength.

Chapter 4 - The Set up menu

This chapter contains the following information:

- General
- Options available
 - Program
 - how to display splice/shrink programs
 - splicing programs
 - pre-defined programs
 - user-definable programs
 - the 9 main steps of splicing
 - splicing parameters
 - primary parameters
 - advanced parameters
 - shrinking programs
 - the 3 main steps of shrinking
 - shrinking parameters
 - how to select and activate a program
 - how to copy a program
 - how to change parameters
 - how to edit a program name
 - Language
 - User
 - how to change basic splicer settings
 - Service
 - reference notes (basic user splicer settings)

General

From the Main menu it is possible for the user to inspect and/or make changes to certain basic splicer settings if necessary.

As the user becomes more experienced, he will need to know how these changes can be made.

This chapter describes the possibilities available when entering the Set up menu via the Main menu (fig. 44).

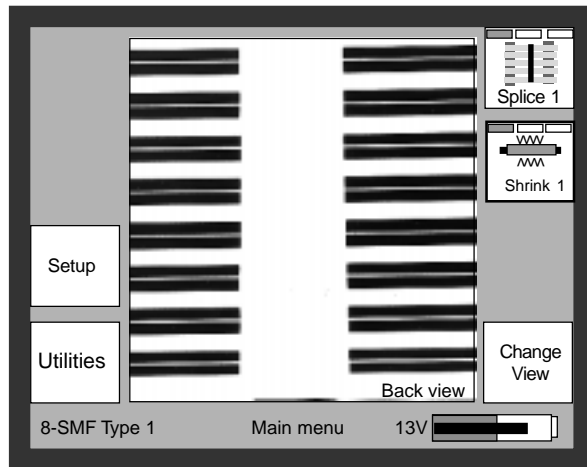

Fig. 43 - Main menu

Options available

From the Main menu press SET UP for access to the following options:

- Program
 - Splice
 - Shrink
 - Proof test (optional)
- Language
- User
- Service (not described here)

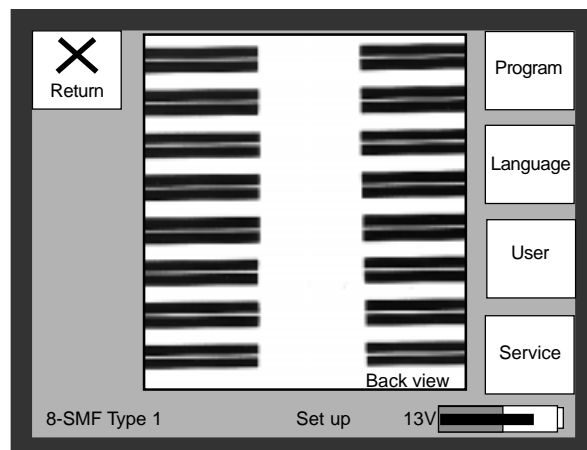

Fig. 44 - Set up menu

Program

Displaying programs on the monitor

To display splice, shrink or proof test (optional) programs on the monitor, from the Set up menu press:

PROGRAM and then

SPLICE (see para. "Splicing programs")

or **SHRINK** (see para. "Shrinking programs")

or **PROOF TEST** (see Appendix C)

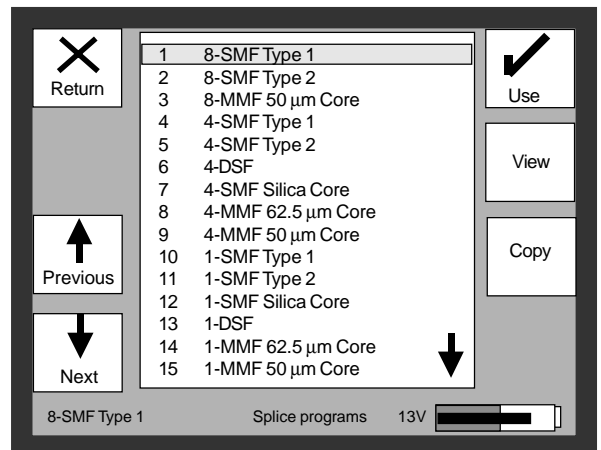

Fig. 45 - Splicing programs displayed on the monitor

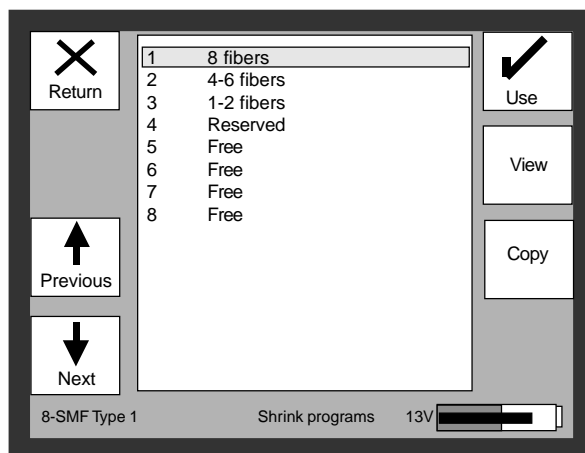

Fig. 46 - Shrink programs displayed on the monitor

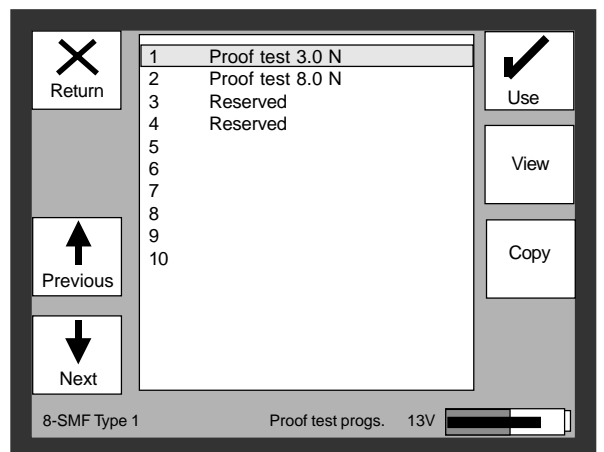

Fig. 47 - Proof test programs displayed on the monitor

From this display, a number of possibilities are now available to the user and are described in this section:

- Selecting a program.
- Copying a program.
- Editing a program name.
- Changing parameters.

Splicing programs

Before starting the splicing process it is important to select the correct program. There are two types of splicing program available: pre-defined and user-definable.

Every splicing program consists of 24 splicing parameters (*see para. "Splicing parameters" pg. 28*) for more details.

Pre-defined splicing programs

The RSU 8 contains 15 pre-defined programs that are optimised for splicing some normal types of fibres. Programs 16 to 20 are reserved for future use.

Note:

A pre-defined program means that the splicing parameters contained in the program are set at the factory and cannot be changed by the user.

User-definable splicing programs

The RSU 8 contains 30 programs (21 to 50), the parameters of which may be edited by the user if necessary. An individual user program may be defined as follows:

1. Copy a pre-defined program to a free program name i.e. 21 to 50 (*see para. "How to copy a program" pg. 33*).
Note:
Choose a pre-defined program that comes as close as possible to your application.
2. Name the chosen program using EDIT NAME (*see para. "How to edit a program name" pg. 35*).
3. Change or adjust the parameters in the new program (*see para. "How to change parameters" pg. 34*).
4. Save and use the new program.

Splicing Prog. No.	Splicing program name
1	8-SMF Type 1*
2	8-SMF Type 2*
3	8-MMF 50 mm Core
4	4-SMF Type 1
5	4-SMF Type 2
6	4-DSF
7	4-SMF Silica Core
8	4-MMF 62.5 mm Core
9	4-MMF 50 mm Core
10	1-SMF Type 1
11	1-SMF Type 2
12	1-SMF Silica Core
13	1-DSF
14	1-MMF 62.5 mm Core
15	1-MMF 50 mm Core
16	Reserved
17	Reserved
18	Reserved
19	Reserved
20	Reserved
21-50	User-definable

Table 1 - Summary of splicing program names and numbers

* Type 1 programs are optimised for either OVD (Outside Vapour Deposition) or VAD (Vapour-phase Axial Deposition) single-mode fibres.

** Type 2 programs are suitable for MCVD (Modified Chemical Vapour Deposition) fibres.

The nine main steps of splicing

The splicing sequence for the RSU 8 consists of 9 main steps which are the same for all splicing programs. These steps are illustrated in fig. 48 and are as follows:

No.	Step	Activity	Parameters
1	Prefusion	The fibres move to the specified gap defined by "Prefuse Distance". The arc lights up and any residual dust on the fibres is blown away.	Prefuse Current Prefuse Distance Prefuse Time
2	Fibre alignment Fibre control	The fibres align axially to a gap defined by the "Gap" parameter. The dirt size, gap, cladding offset and cleave angles for all the fibres are measured.	Gap Dirt Size Limit Cladding Offset Limit Cleave Angle Limit Cleave Length Difference Limit
3	Close	The arc lights up and the fibres move forwards and touch.	Gap Overlap Current
4	Overlap	The fibres push together and overlap each other to the distance defined by "Overlap Distance".	Overlap Current Overlap Distance Overlap Time
5	Main Fuse 1	The fibres are heated up <i>almost</i> to the temperature needed to melt glass.	Fuse Time 1 Fuse Current 1
6	Pull	The fibres pull apart to the distance defined by "Pull".	Pull
7	Main Fuse 2	The arc power increases and the fibres heat up to the glass melting temperature.	Fuse Time 2 Fuse Current 2
8	Relax (optional)	The arc power decreases and the fibres anneal.	Relax Current Relax Time
9	Estimation	The stored hot and cold images are processed and the splice loss is estimated according to the parameters "Estimation Method" and "Fiber Type".	Fiber Type Estimation Method Left MFD Right MFD

Table 2 - Summary of the main steps of the splicing process

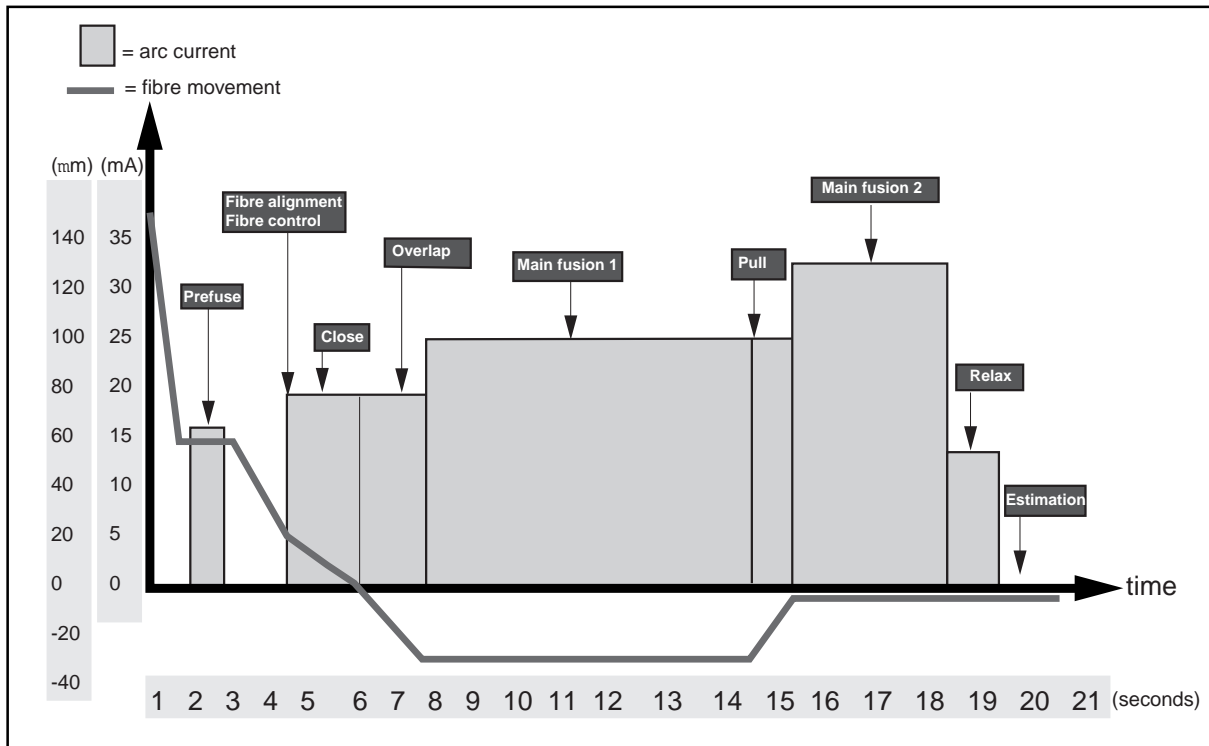

Fig. 48 - Schematic of the splicing process showing the arc current and the fibre movement

Splicing parameters

All splicing programs contain a number of parameters which define how the splicing process is carried out.

The splicing parameters (24 in total) are divided into primary and advanced parameters.

The primary parameters (see Table 3) define the following activities:

- pre-fusion
- gap
- overlap
- fusion sequences
- pull sequence
- relax

The advanced parameters (see Table 4) define:

- camera control
- fibre geometry and alignment control
- estimation
- fibre type

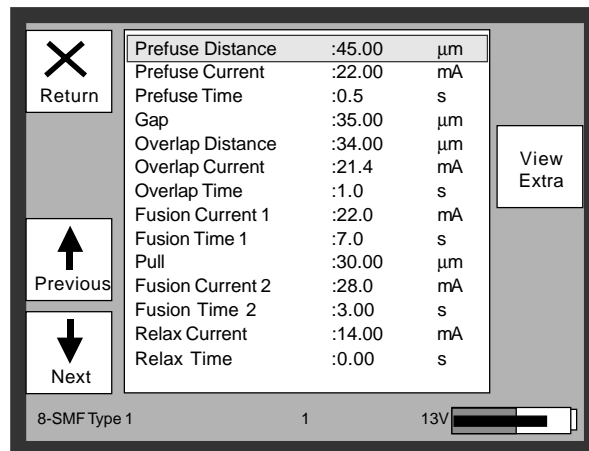

Fig. 49 - Monitor after pressing VIEW (showing primary splicing parameters)

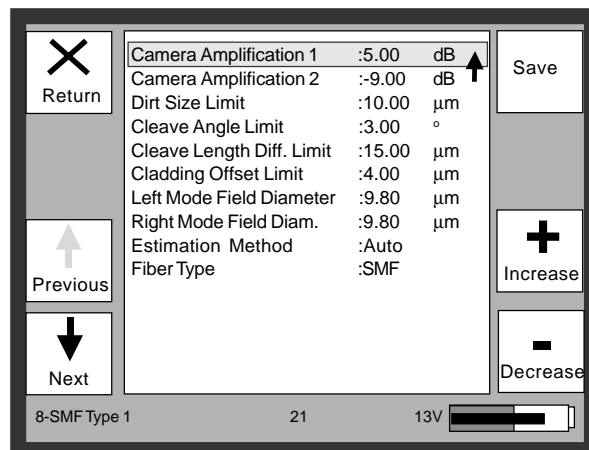

Fig. 50 - Monitor after pressing VIEW EXTRA (showing primary and advanced parameters)

Primary splicing parameters

No.	Primary parameter	Unit	Range	Step
1	Prefuse Distance	µm	10 - 200	5
2	Prefuse Current	mA	10 - 30	0.4
3	Prefuse Time	s	0.1 - 5	0.1
4	Gap	µm	0 - 100	1
5	Overlap Distance	µm	2 - 100	2
6	Overlap Current	mA	10 - 30	0.2
7	Overlap Time	s	0.1 - 5	0.1
8	Fusion Current 1	mA	10 - 30	0.2
9	Fusion Time 1	s	1 - 20	0.5
10	Pull	µm	0 - 100	2
11	Fusion Current 2	mA	10 - 35	0.2
12	Fusion Time 2	s	1 - 20	0.5
13	Relax Current	mA	10 - 20	0.2
14	Relax Time	s	0 - 10	0.5

Table 3 - Primary splicing parameter overview

Advanced splicing parameters

The following parameters influence camera control, fibre geometry control, fibre alignment control and estimation. They are displayed after pressing VIEW EXTRA.

No.	Advanced parameter	Unit	Range	Step
15	Camera Amplification 1	dB	-15 - +25	0.2
16	Camera Amplification 2	dB	-30 - +10	0.2
17	Dirt Size Limit	µm	0 - 50	2
18	Cleave Angle Limit	°	0 - 5	0.1
19	Cleave Length Difference Limit	µm	0 - 30	2
20	Cladding Offset Limit	µm	0 - 20	0.2
21	Left Mode Field Diameter	µm	2 - 20	0.1
22	Right Mode Field Diameter	µm	2 - 20	0.1
23	Estimation Method	-	*	-
24	Fiber Type	-	**	-

Table 4 - Advanced splicing parameter overview

* Auto, core and cladding

** SMF, DSF, Multimode, True Wave and Leaf

Shrinking programs

Before using the heat oven it is important to select the correct shrinking program. In the same way as for splicing programs, the RSU 8 provides both pre-defined and user-definable shrinking programs.

Every shrinking program consists of 3 parameters (see para. "Shrinking parameters") for more details.

Shrinking prog. no.	Shrinking prog. name
1	8 fibres
2	4-6 fibres
3	1-2 fibres
4	Reserved
5-8	User-definable

Table 5 - Shrinking programs

The three main steps in the shrinking sequence

The shrinking sequence consists of 3 steps:

1. warming up
2. melting
3. cooling

A lamp signalling system is located on top of the heat oven (see Table 6).

Activity	Status of lamp
heat oven is ready for use	green
shrinking process starts	yellow
until melting sequence ends	remains yellow
cooling sequence starts	flashing yellow
shrinking process finished (a signal is heard)	green

Table 6 - Lamp signalling system overview

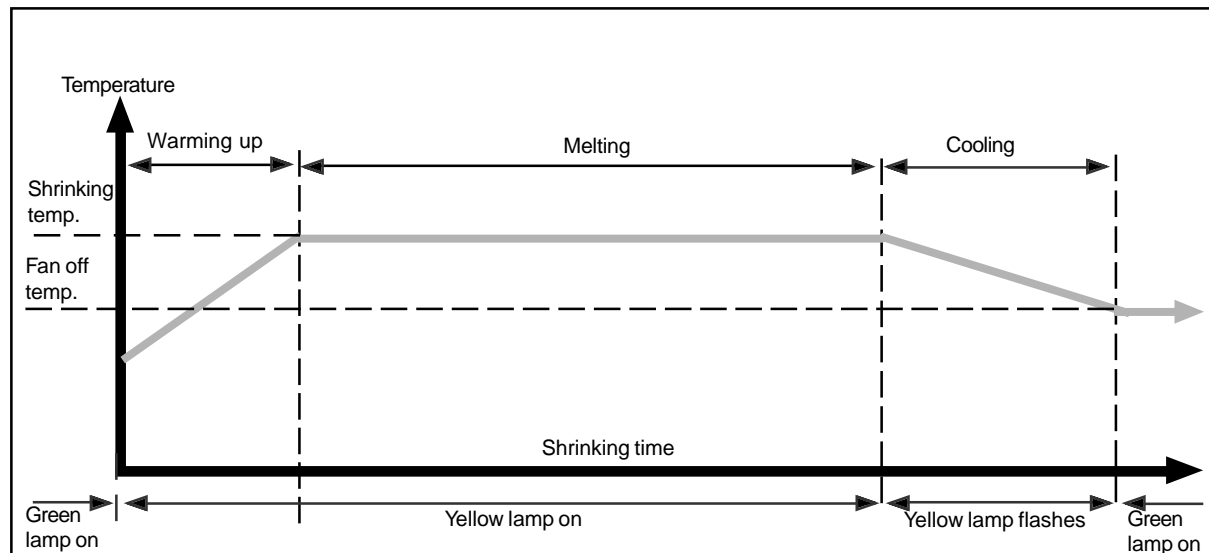

Fig. 51 - Schematic illustrating the heat oven (shrinking) sequence

Shrinking parameters

No.	Parameter	Unit	Range	Step
1	Shrinking temperature	°C	80 - 170	1
2	Shrinking time	s	10 - 300	1
3	Fan off temperature	°C	20 - 150	1

Table 7 - Shrinking parameter overview for shrinking programs

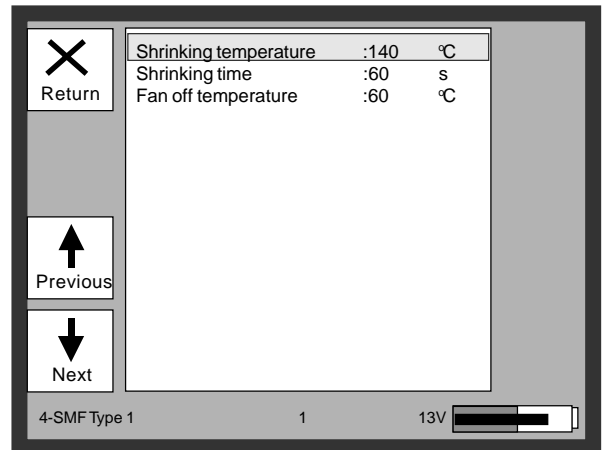

Fig. 52 - Monitor after pressing VIEW showing shrinking parameters

How to select and activate a program

1. From the Main menu press:
SETUP
2. From the Set up menu press:
PROGRAM
3. To display the list of splicing or shrinking programs press:
SPLICE or SHRINK or
PROOF TEST (see Appendix C)
4. Highlight the desired program by pressing either:
PREVIOUS or NEXT
5. To load the selected program, press:
USE

Note:

The current splice program **name** is always displayed in the status bar on the screen. The current splice and shrink program **number** is displayed in the splice and shrink function icons in the Main menu.

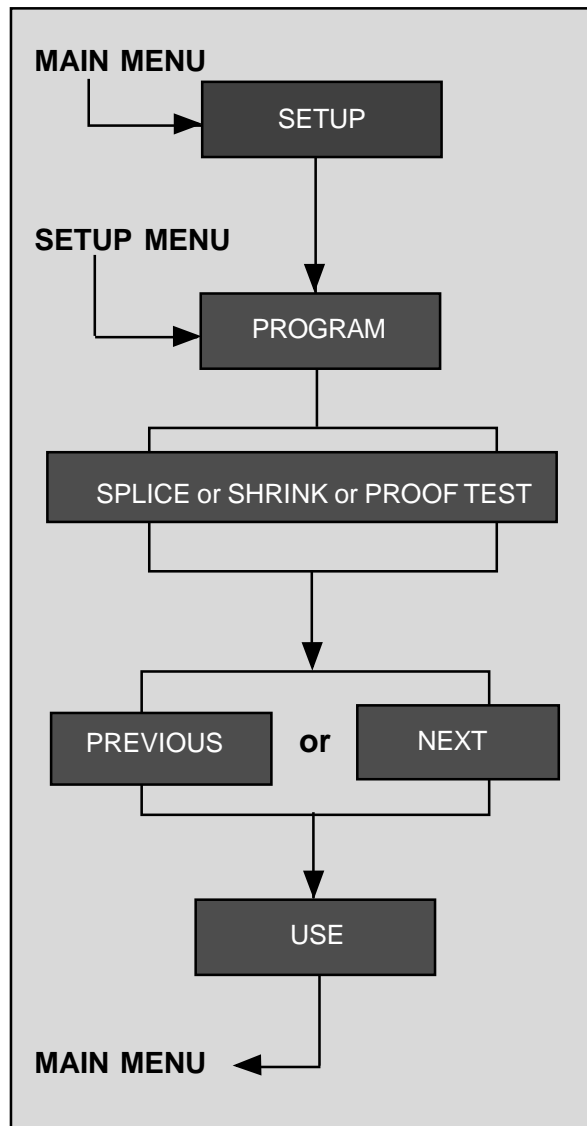

Fig. 53 - Flow chart of procedure for selecting a pre-defined program

How to copy a program

1. From the Main menu press:
SETUP
 2. From the Set-up menu press:
PROGRAM
 3. To display the list of splicing or shrinking programs, press:
SPLICE or SHRINK or
PROOF TEST (see Appendix C)
 4. Highlight the program to be copied by pressing:
PREVIOUS or NEXT
 5. Copy the chosen program by pressing:
COPY
 6. Highlight a free (user-definable) program number where the copied program is to be stored by pressing:
PREVIOUS or NEXT
- Note:**
All parameters in the selected program are overwritten.
7. To save the copied program under the free program, press:
SAVE AS
 8. To edit the copied program see para. *"How to change parameters"*.
 9. To name this new program see para. *"How to edit a program name"*.
 10. Return to the Main menu by pressing:
USE

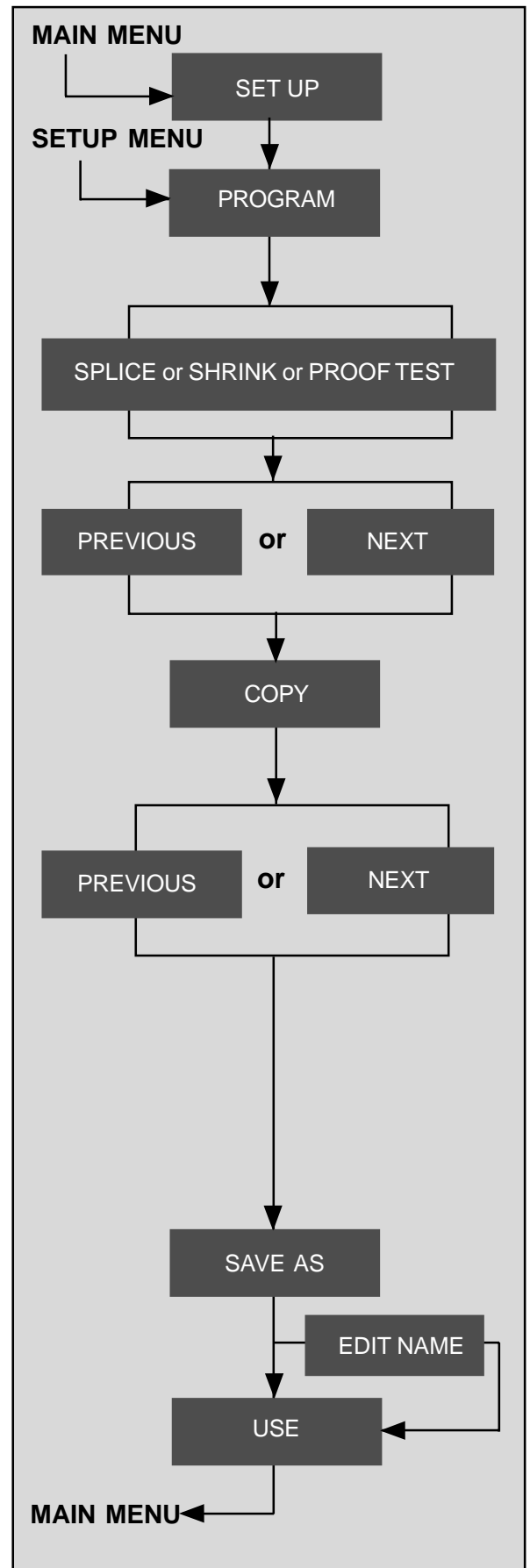

Fig. 54 - Flow chart of procedure for copying a program

How to change parameters

1. From the Main menu press:
SET UP
2. From the Set-up menu press:
PROGRAM
3. Display the list of programs by pressing:
SPLICE, SHRINK or
PROOF TEST (see Appendix C)
4. Select the program where the parameters are to be edited by pressing:
PREVIOUS or NEXT
5. To see the list of primary parameters press:
VIEW
- Note:**
Press VIEW EXTRA for a list of all splicing parameters
6. Move to the desired parameter by pressing:
PREVIOUS or NEXT
7. Change the parameter value by pressing:
INCREASE or DECREASE
8. When all parameters are edited press:
SAVE
9. Return to Main menu by pressing:
USE

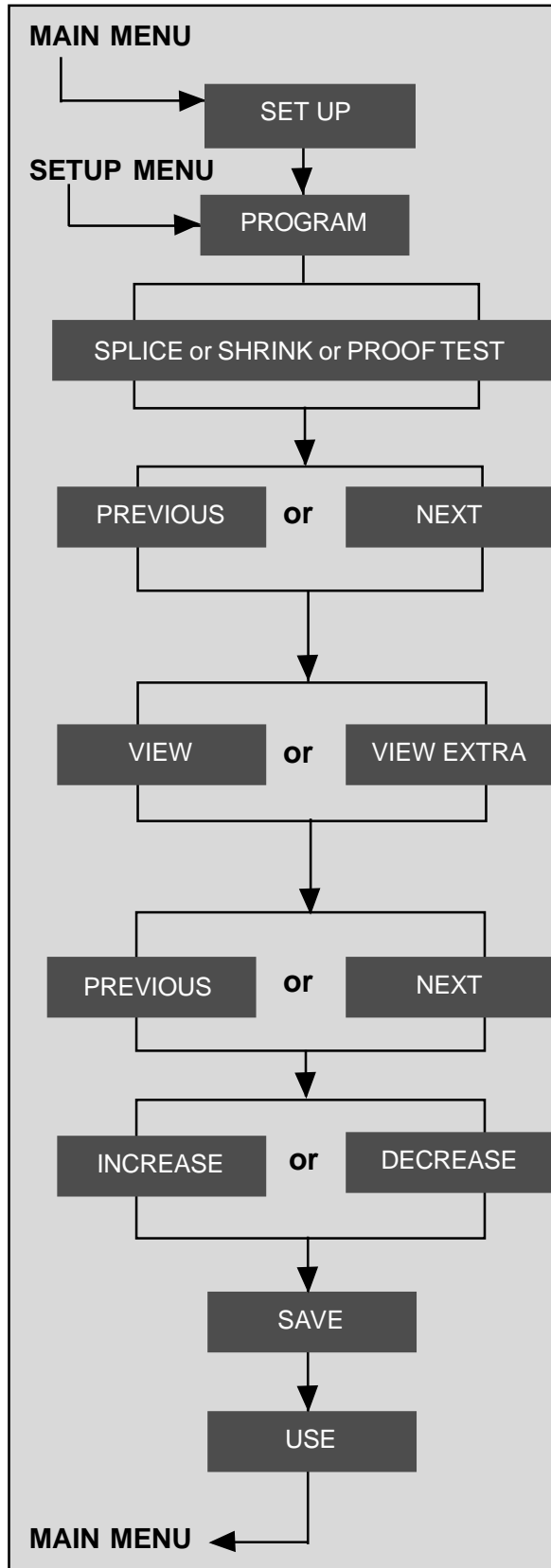

Fig. 55 - Flow chart of the procedure for changing parameters

How to edit a program name

Any user-definable (free) splicing or shrinking program can be named as follows:

1. From the Main menu, press:
SET UP
2. From the Set-up menu, press:
PROGRAM
3. To display the list of splicing or shrinking programs press:
SPLICE or SHRINK or
PROOF TEST (see Appendix C)
4. Highlight the program number to be named by pressing:
PREVIOUS or NEXT
5. Press:
EDIT NAME
6. Move through and select the letters and digits by pressing:
INCREASE or DECREASE
- Note:**
To speed up character selection, hold down the Increase or Decrease buttons.
7. Move the cursor to the next character in the name by pressing:
PREVIOUS or NEXT
8. When the program name has been edited, press:
SAVE

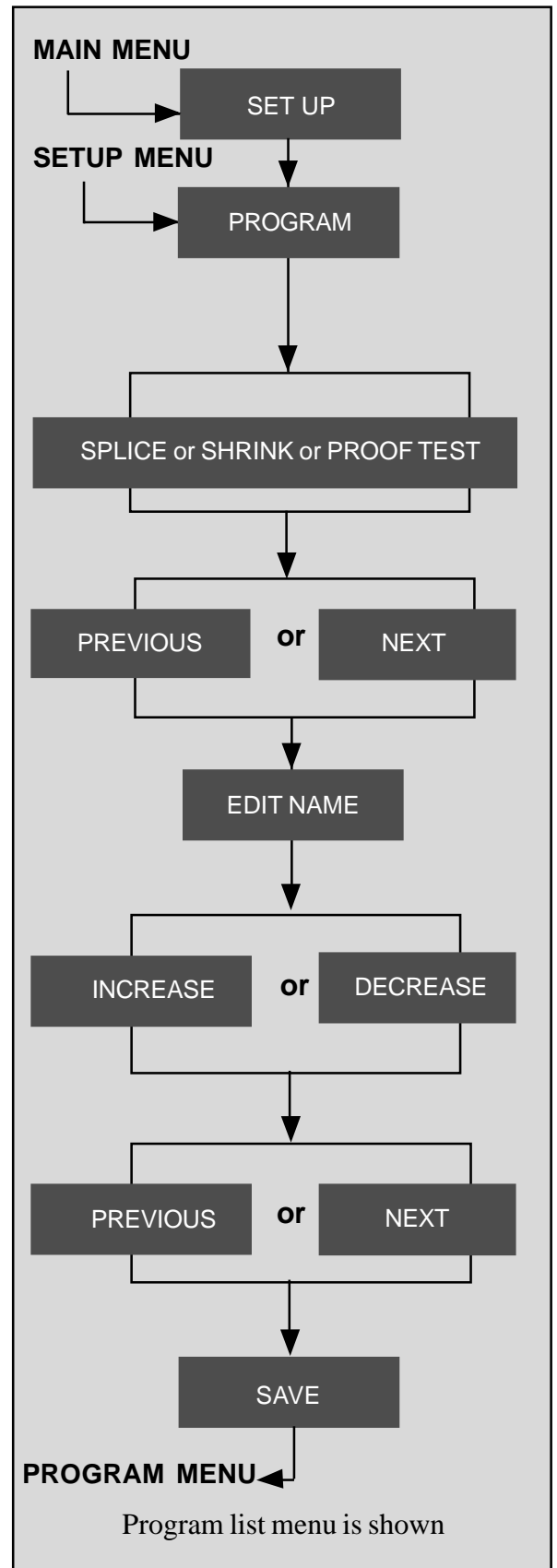

Fig. 56 - Flow chart of procedure for editing a program name

Language

The RSU 8 can be adapted, via the "Language" application for using the Swedish, English and Chinese languages.

The user can change languages by following a few basic steps as described below.

1. From the Main menu enter Set up menu by pressing:
SETUP
2. From the Set up menu, enter Language menu by pressing:
LANGUAGE
4. Select the appropriate language by pressing:
PREVIOUS or **NEXT**
5. To confirm the language selection press:
OK

Note:
The monitor returns to the Main menu automatically.

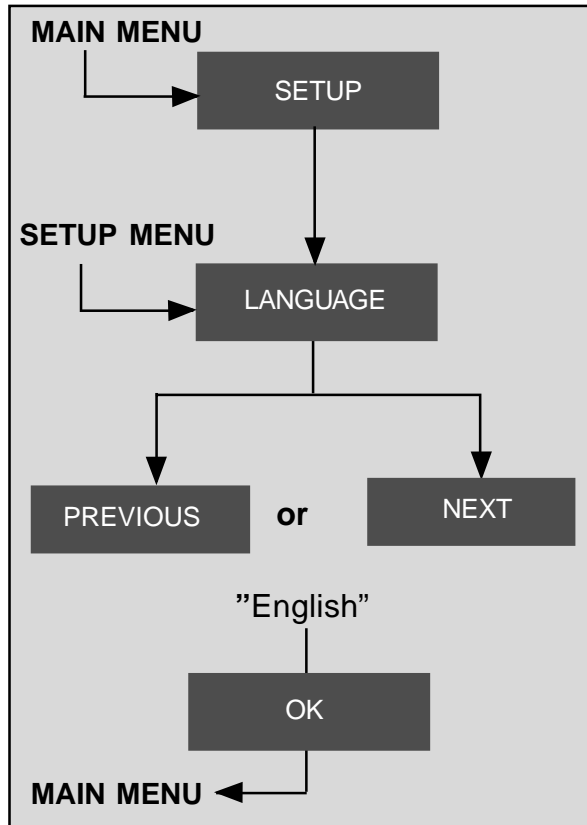

Fig. 57 - Flow chart of procedure for selecting a language

User

The "User" application allows the user to adjust some basic splicer parameters (*see Table 8, page 38*).

Any changes made are "global" and affect all the splicing programs.

Note:

See Reference Notes on page 38 for details of these basic splicer parameters.

How to change basic splicer parameters

1. From the Main menu, enter the Set-up menu by pressing:
SET UP
2. To display the basic splicer parameters on the monitor press:
USER
3. Select the parameter to be changed from the list by pressing:
PREVIOUS or NEXT
4. Change the chosen value by pressing:
INCREASE/ON or DECREASE/OFF
5. When all the values have been changed, press:
SAVE

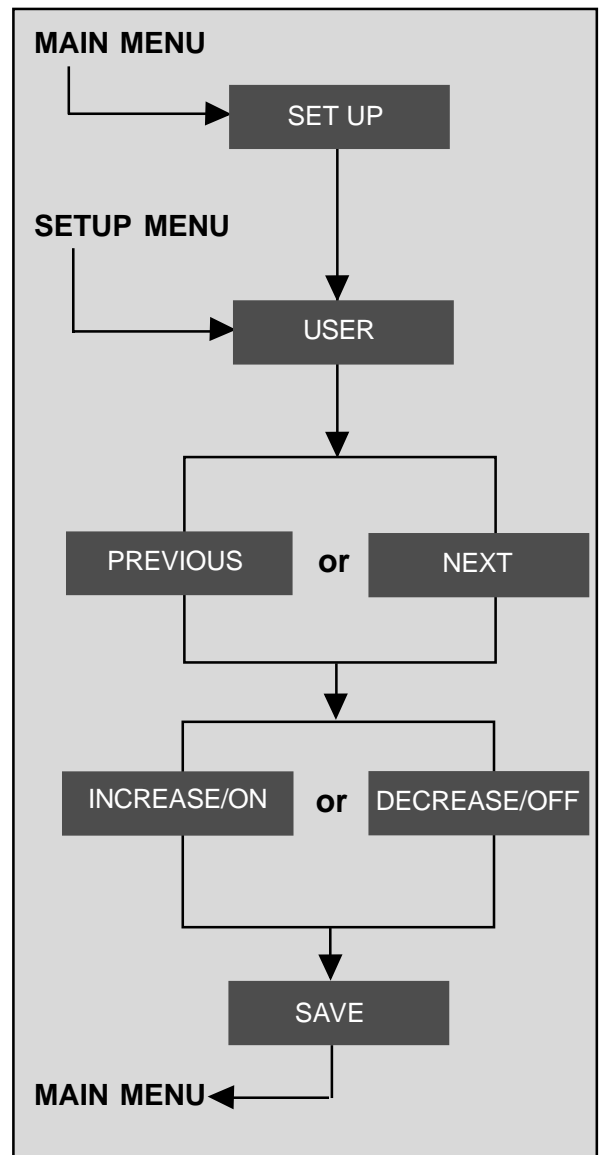

Fig. 58 - Flow chart of procedure for changing basic splicer parameters

Service

The "Service" application is not described in this manual and is only intended for authorised service personnel.

Reference notes

Basic user parameters

No	Parameter	Description	Unit	Default	Range	Step
1	Pause before fusion	If set to "On" then the splicing sequence will always stop just before fusion to allow the user to examine the fibres before continuing the splicing process.	-	Off	On/Off	-
2	Show all estimated losses	The RSU 8 automatically calculates the splice loss values after the splicing sequence. If this setting is "On" then all estimation values are automatically displayed on the monitor. If this setting is "Off" then only values larger than the "Min. shown est. loss" are displayed. In this way the user is informed of a bad splice	-	Off	On/Off	-
3	Minimum shown estimated loss	(see above)	dB	0.2	0 - 1.0	0.1
4	Lamp level	Adjusts the intensity of light in V-groove area.	%	70	0 - 100	5
5	Display contrast	Adjusts the display contrast by changing the brightness of the display's back lighter.	%	80	0 - 100	1
6	Power save wait	The period of time before the monitor and cameras are switched off.	min.	2	0* - 120	1
7	Turn off wait	The period of time before the splicer switches off completely.	min.	5	0* - 120	1
8	Date	To see and adjust the date on the monitor.	-	-	1990-2089	1
9	Time	To see and adjust the time on the monitor.	-	-	0 - 24	1
10	Splice count	Calculates all the splicing sequences and is reset to zero after changing electrodes.	-	-	0 - 10 ⁹	-
11	Total count	Total number of splicing sequences carried out during the splicer's lifetime - cannot be reset to zero.	-	-	0 - 10 ⁹	-
12	Battery warning limit	Warns the user when battery voltage falls below this limit.	volt	11.4	11 - 13	0.1
13	Oven lamp	The heat oven lamps can be lit to observe the shrinking process.	-	Off	On/Off	-
14	Sound	Turns off the audible signal.	-	On	On/Off	-
15	Decimal character	The splice result can be saved with either a comma or fullstop as a separator (see Disk Utilities).	-	.	,/.	-

Table 8 - Basic user splicer parameters

0* = Infinite time

Chapter 5 - The Utilities menu

This chapter contains the following information:

- General
- Electrode cleaning
- Auto current adjustment
 - procedure
 - reference notes
- Images from last splice
- Read sensors
- Manual splicing
- Splice results
- Disk utilities
 - saving a splice result onto a disk
 - saving a splice result under an existing directory
 - saving a splice result under a new directory
 - saving a splice result under the root directory
 - saving splice results between specific dates
 - saving a splice program onto a disk
 - reading a splice program from the disk into the splicer
- error messages
- Adjust arc position
- Calibrate motors

General

From the Main menu press UTILITIES.

It is now possible for the user to carry out a number of utilities as shown in fig. 60.

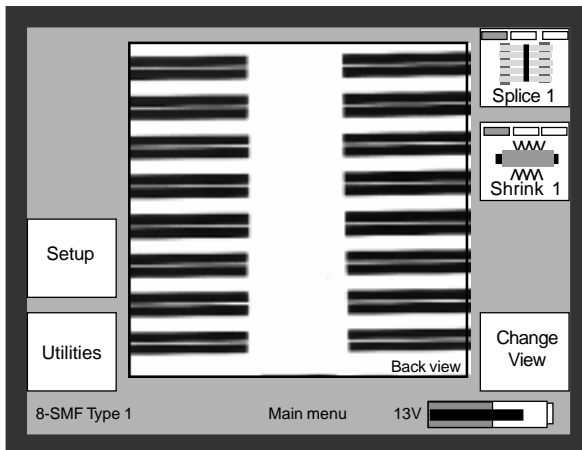

Fig. 59 - Main menu

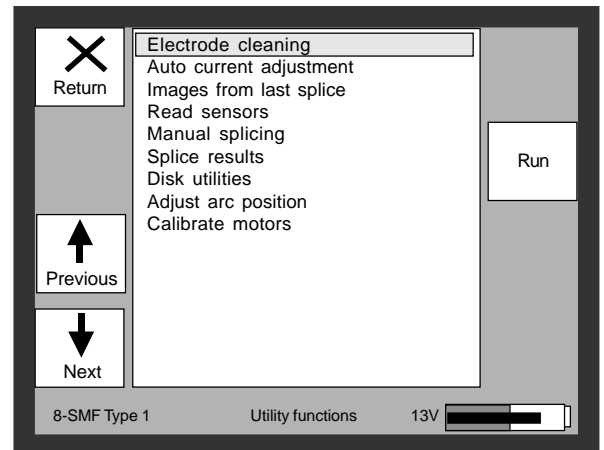

Fig. 60 - Utilities menu

Electrode cleaning

The electrode cleaning program burns away the deposits on the tips of the electrodes.

Run this program:

- after about 10 to 20 splices (depending on the fibre used)
- if the current (light), is unstable (i.e. jumps)
- if the electrodes make a "sizzling" noise.

1. Ensure there are no fibres in the splicer.
2. From the Main menu, enter the Utilities menu by pressing:

UTILITIES

3. Execute the "Electrode cleaning" utility (which is already highlighted) by pressing:

RUN

Note:

The arc is lit for 6 seconds and has 2 different currents. If there is still a low sizzling sound, run the cleaning program again by pressing RUN.

5. To end the cleaning program and return to the Utilities menu, press:

RETURN

6. To return to the Main menu, press:

RETURN

Note:

After approximately 200 splices, remove the electrodes and brush or polish them (see Chapter 6 "Maintenance").

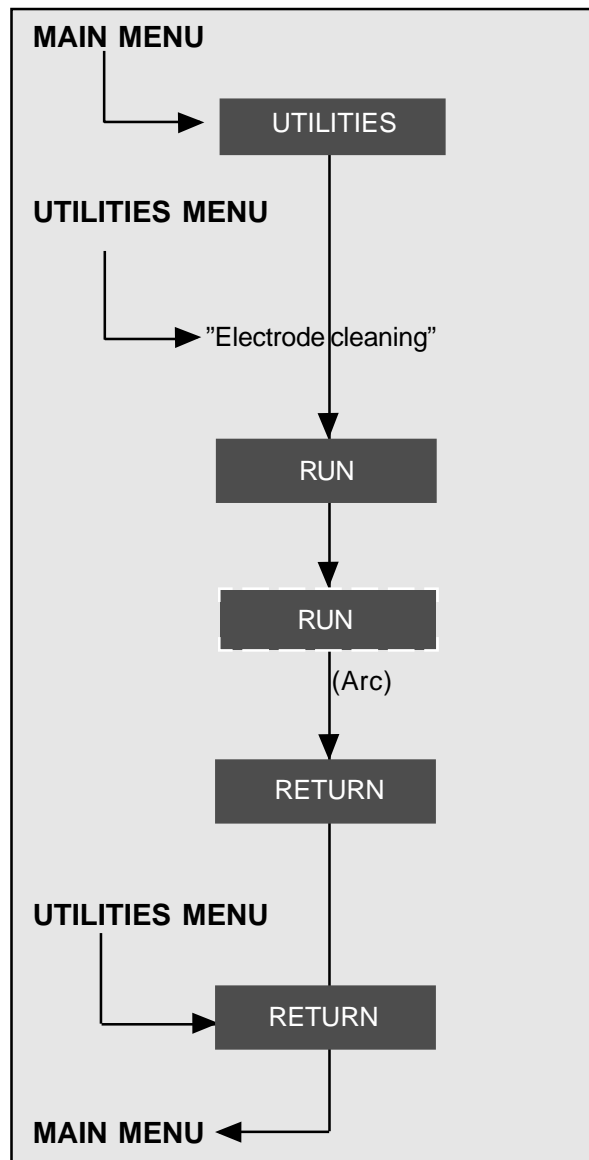

Fig. 61 - Flow chart of procedure for running the electrode cleaning program

Auto current adjustment

The Auto current adjustment utility automatically adjusts the fusion currents by processing the images of the hot fibres during Main fusion 1 and Main fusion 2.

Procedure

1. Ensure the lenses of the cameras are clean (*see Chapter 6 "Maintenance"*).
2. Place stripped and thoroughly clean whole fibres in the splicer (fig. 62).
3. Select "Auto current adjustment" utility from the Utilities menu (see fig. 60).

This utility should be run:

- daily
- when new fibre types are used
- when splicing in new environments
- after changing electrodes

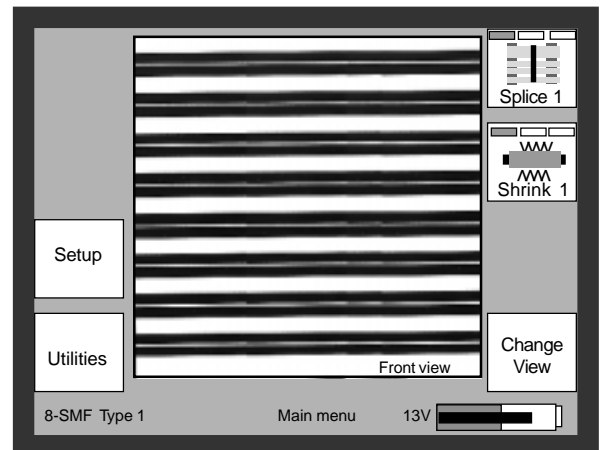

Fig. 62 - Stripped and cleaned fibres in the splicer

4. A live front camera image and current adjustment value is shown on the display (fig. 63).

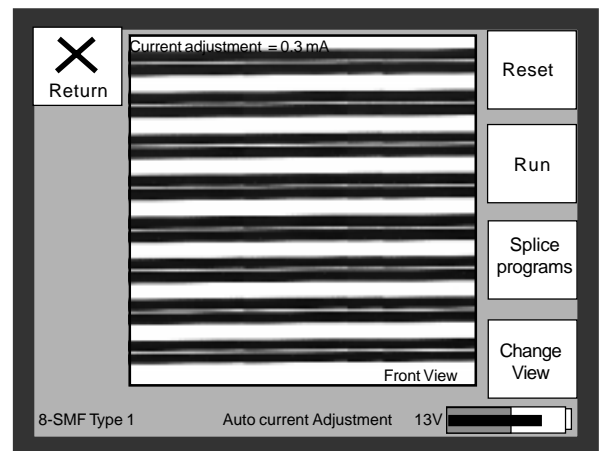

Fig. 63 - Starting current value and live image

5. Press:
RUN

Note:

The splicer analyses the images and controls the number of fibres, their position and if the correct splicing program has been chosen. The user is warned if something is not correct (fig. 64).

To stop this utility and go to the "Splice programs" menu, press ABORT SPLICE and PROGRAMS.

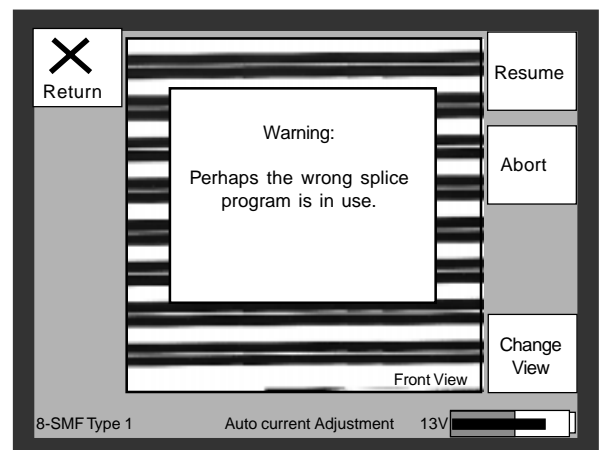

Fig. 64 - Warning message

- 6. To remove the warning message and continue the Auto current adjustment utility, press:

RESUME

- 7. A hot image of the fibres is presented on the monitor (fig. 65)

Note:

Refer to Reference Notes to understand how the splicer automatically adjusts the Current Adjustment Value.

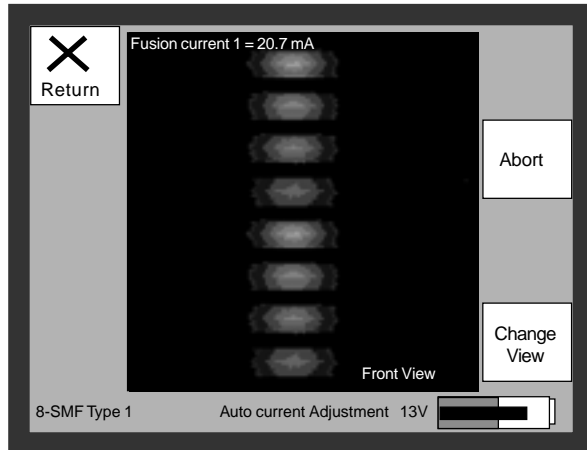

Fig. 65 - Hot image of fibres showing fusion current

- 8. The new Current Adjustment Value is displayed on the monitor as shown in fig. 66.
- 9. To set the default Current Adjustment value 0 mA (i.e. no adjustment) press:

RESET

- 10. To examine the saved hot images with "Fusion Current 1" and "Fusion Current 2", press:

IMAGES

Note:

ZOOM and PROFILE have the same functions as described in Chapter 3 "Evaluating the splice".

- 11. To return to the Utilities menu, press:

RETURN

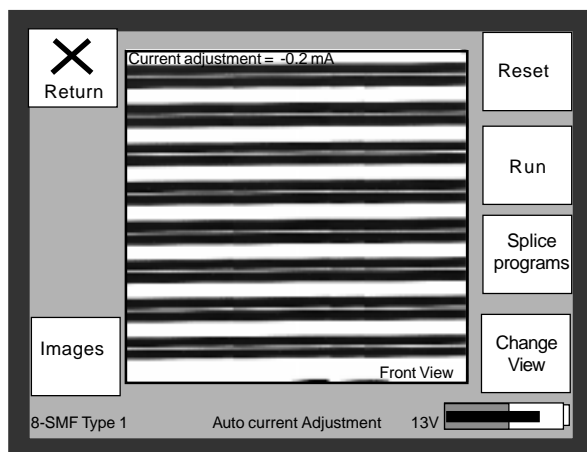

Fig. 66 - Monitor showing new Current Adjustment Value

Reference notes**How the splicer automatically adjusts the Current Adjustment Value**

1. Starting from the splice program's Fusion Current 1 parameter value plus the old Current Adjustment Value, the current is either increased or decreased until the correct fibre brightness value is reached.
Note:
The fibre brightness value is pre-set at the factory in the pre-defined splice programs.
2. The amount of current needed to reach this fibre brightness value is compared to the previously mentioned Fusion Current 1 value.
3. The difference between these two current values is noted.
4. Starting from the splice program's Fusion Current 2 parameter value plus the difference calculated in step 3, the current is either increased or decreased until the correct fibre brightness value is reached.
5. The amount of current needed to reach this fibre brightness value is compared to the previously mentioned Fusion Current 2 value.
6. The difference between these two current values is noted.
7. The average value of the two differences mentioned in steps 3 and 6 give the new Current Adjustment Value.
Note:
This value will be used as a correction for all current values in the splice programs.

Images from last splice

This utility enables the user to enter the Images window and see hot and/or cold images taken during the previous splice (see Chapter 3 "Evaluating the splice").

Note:

These images are lost if the Auto current adjustment utility is run.

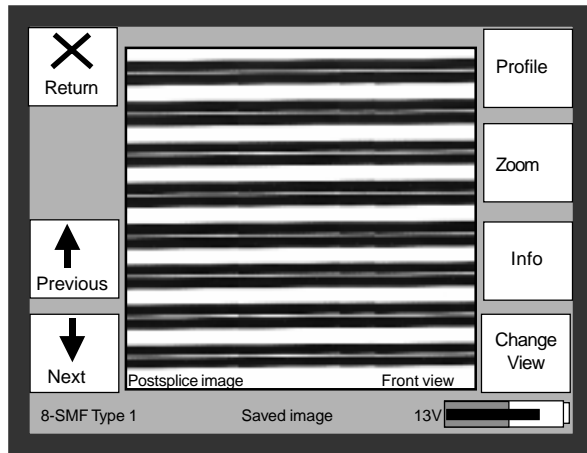

Fig. 67 - Monitor after choosing "Images from last splice"

Read sensors

This utility measures and displays the ambient air pressure and the splicer's internal temperature. A cooling fan is started if the internal temperature becomes too high.

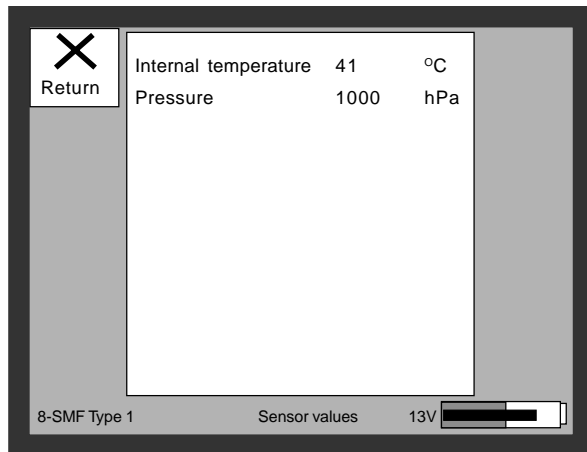

Fig. 68 - Monitor after selecting "Read sensors"

Manual splicing

Splicing in the manual mode is not so usual, although this may be necessary in special cases.

Manual splicing allows the user to align and control the fibres manually on the monitor before the splicing sequence commences. Refer to fig. 71 for a schematic illustration of the manual splicing process.

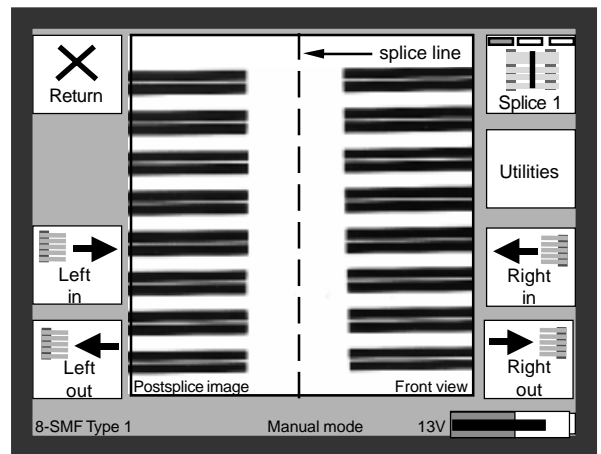

Fig. 69 - Monitor after selecting "Manual splice"

1. Select the "Manual splicing" from the Utilities menu as described previously, and press:

RUN

2. Put stripped and cleaved fibres into the splicer.

3. Show the fibre alignment line on the monitor by pressing:

UTILITIES and SPLICE LINE SHOW

2. Move the fibres towards the splice line by pressing:

LEFT IN or LEFT OUT and
RIGHT IN or RIGHT OUT

3. Remove the fibre alignment line (optional) by pressing:

UTILITIES and SPLICE LINE HIDE

4. Visually evaluate fibre alignment.

Note:

Change views by pressing CHANGE VIEW. If necessary press the fibre adjustment buttons on the safety shield.

5. To execute manual splicing press:

SPLICE

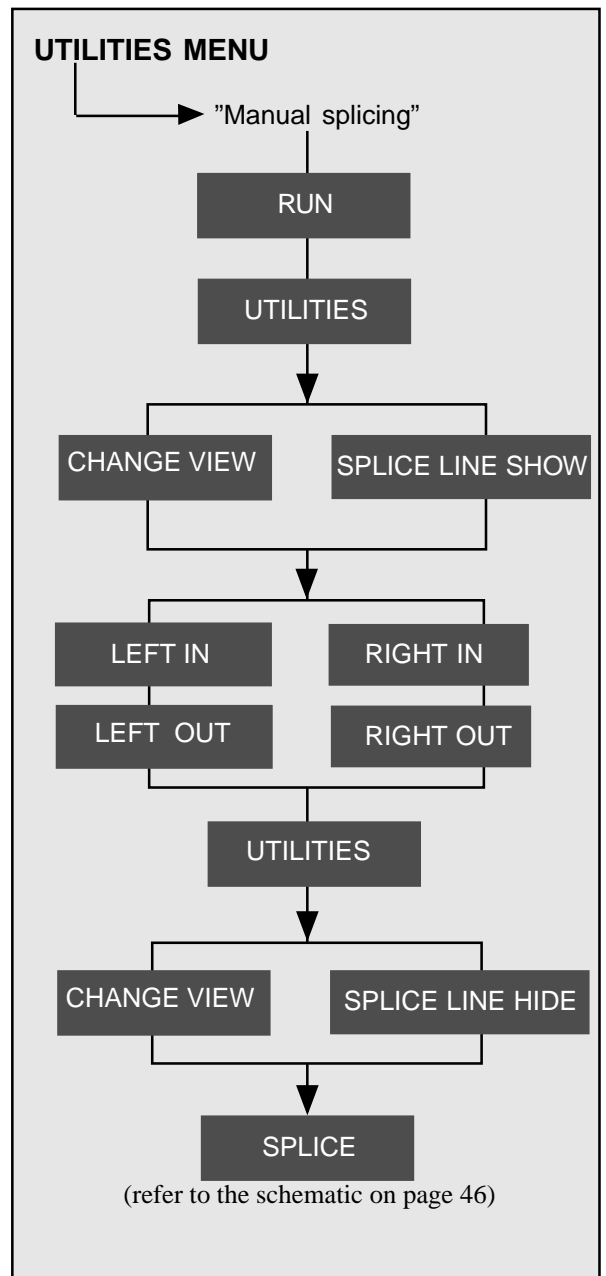

Fig. 70 - Flow chart of procedure for manual splicing

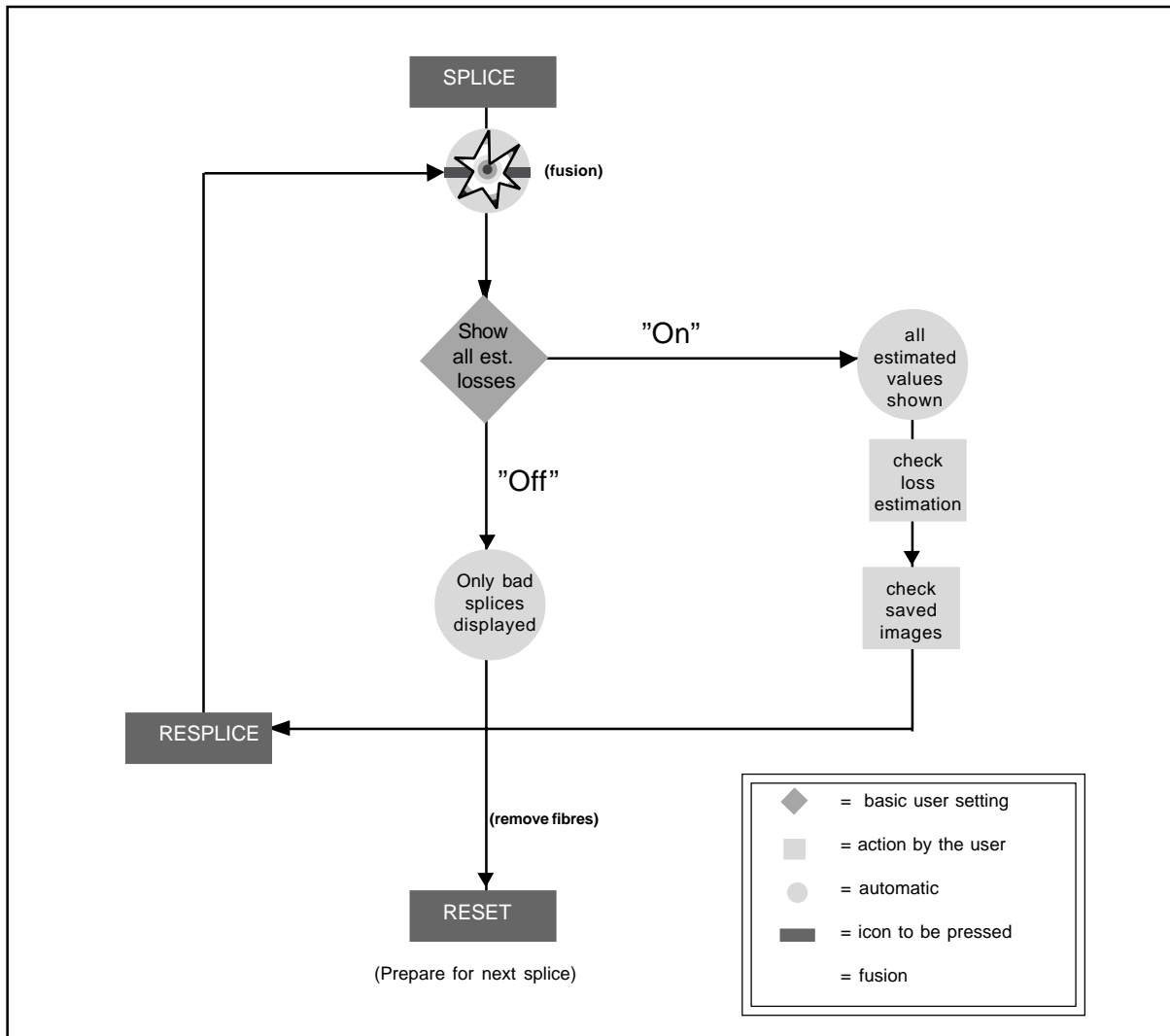

Fig. 71 - Schematic over manual splicing procedure

Splice results

This utility enables the user to read splice results from the internal memory. Data for up to 500 splices can be stored in the splicer's memory.

A list of the saved splicing results is shown on the monitor as in fig. 72.

1. Select the "Splice results" from the Utilities menu as described previously.
2. Move up or down the list to select the desired splicing result by pressing:

PREVIOUS or NEXT

	date	time	splice program used	largest estimated value for this splice
Return	1998-06-29	16.59	Prog 4	0,05
	1998-06-29	15.38	Prog 4	0,06
	1998-06-29	14.37	Prog 4	0,02
	1998-06-29	13.40	Prog 4	0,02
	1998-06-29	12.09	Prog 4	0,03
	1998-06-29	11.30	Prog 4	0,05
	1998-06-29	10.08	Prog 4	0,08
	1998-06-29	09.09	Prog 4	0,01
	1998-06-29	08.03	Prog 4	0,05
	1998-06-29	07.58	Prog 4	0,04
	1998-06-29	06.50	Prog 4	0,04
	1998-06-29	05.47	Prog 4	0,02
	1998-06-29	04.30	Prog 4	0,03
	1998-06-29	03.20	Prog 4	0,07
	1998-06-29	02.09	Prog 4	0,04
	1998-06-29	01.48	Prog 4	0,06

8-SMF Type 1 Splice results 13V

Fig. 72 - Monitor displaying last splicing results

3. To display the information about the splicing result, press:

VIEW

Note:

Information about the splicing result highlighted in fig. 72 is shown on the monitor as illustrated in fig. 73.

4. To return to the main menu, press:

RETURN

Note:

Splicing data can be saved on a diskette (see pg. 49).

Return	Time	1998-06-29	13:08
	Splice program	4	
	Fiber 1	0.05	dB
	Fiber 2	0.04	dB
	Fiber 3	0,01	dB
	Fiber 4	0,03	dB
	Fiber 5	0,02	dB
	Fiber 6	0,01	dB
	Fiber 7	0,03	dB
	Fiber 8	0,02	dB
	Internal temperature	40	°C
	Pressure	1011	hPa

8-SMF Type 1 Splice results 13V

Fig. 73 - Individual splicing result (after pressing VIEW)

Disk Utilities

This utility enables the user to access the disk station mounted inside the RSU 8.

The following functions are available:

Note:

Only formatted 1.44 MB HD or 720 kB DD may be used.

- *saving a splice result onto a disk*
- *saving a splice result under an existing directory*
- *saving a splice result under a new directory*
- *saving a splice result under the root directory*
- *saving splice results between specific dates*
- *saving a splice program onto a disk*
- *reading a splice program from the disk into the splicer*
- *error messages*

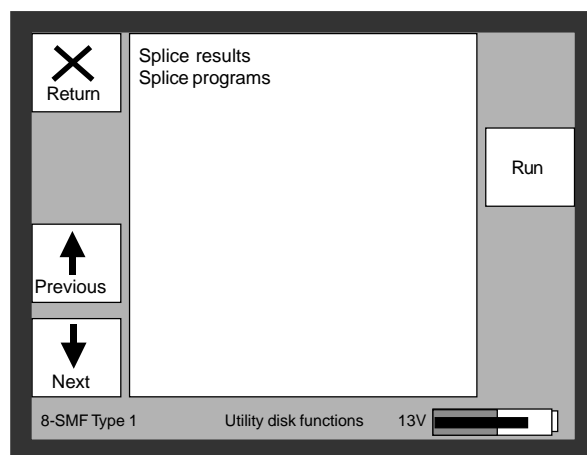

Fig. 74 - Monitor display after selecting "Disk utilities"

Saving a splice result onto a disk

1. From the Disk utilities menu select the text "Splice results" and press:

RUN

2. The monitor changes as illustrated in fig. 75. At this point the window is empty and the user can choose to save the result either:

- under a directory already existing on the disk
- under a new directory
- directly onto the disk under the root directory
- according to a special date

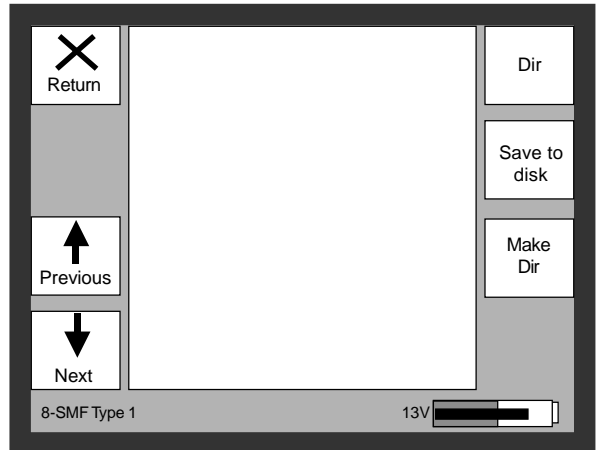

Fig. 75 - Monitor display after pressing RUN

Note:

The splice result can be saved with either a fullstop or comma as a separator (see pg. 38).

Saving a splice result under an existing directory

3. Press:

DIR

Note:

The contents of the disk is now displayed on the monitor as in fig. 76.

- RES (splice result)
- PRG (splice program)
- <DIR> (directory)
- <VOL> (label)

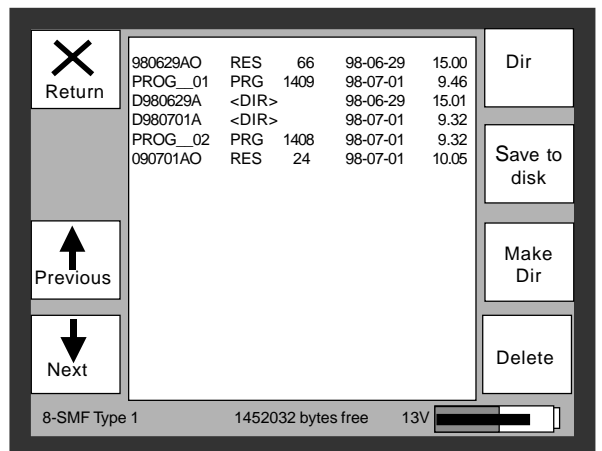

Fig. 76 - Contents of the disk after pressing DIR

4. Select a directory (<DIR>) where the splice result is to be stored and press:

DIR

Note:

The contents of the chosen directory are displayed on the monitor as in fig. 77. In this example the directory is empty.

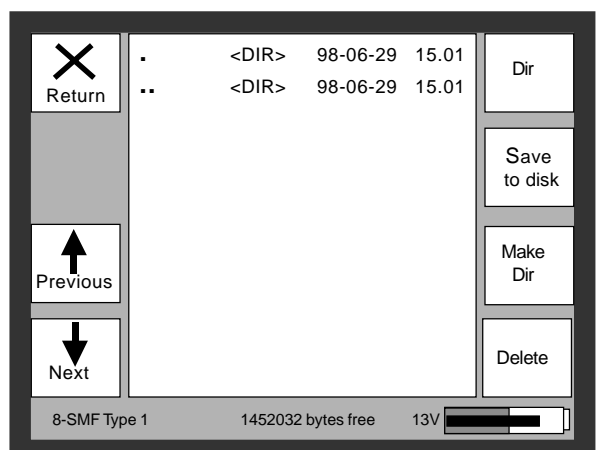

Fig. 77 - Contents of the chosen directory

5. Press:

SAVE TO DISK

Note:

The monitor shows the splicing results from the splicer.

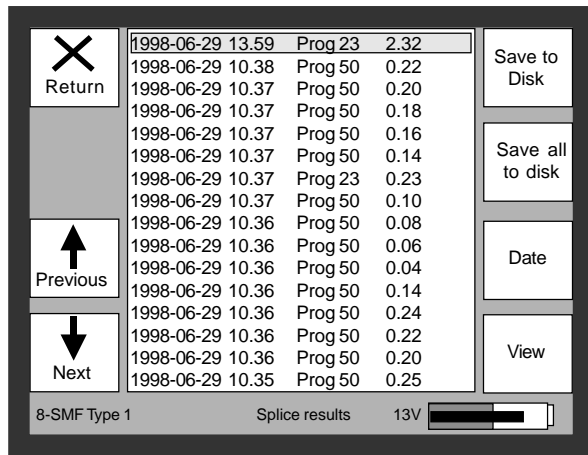

Fig. 78 - Monitor showing saved splicing results

6. Full details of the chosen splice result can be seen by pressing:

VIEW and RETURN

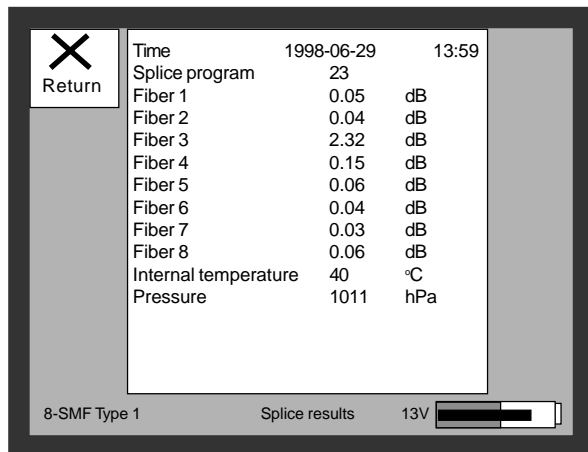

Fig. 79 - Full details of a splice result

7. Select the splice result to be saved by pressing:

PREVIOUS or NEXT and then,

SAVE TO DISK

Note:

To save all the splice results press: SAVE ALL TO DISK .

8. A suggested file name appears on the monitor. However, this can be changed if desired by moving the cursor (-) forwards or backwards with the help of the right and left arrows and then pressing:

INCREASE or DECREASE

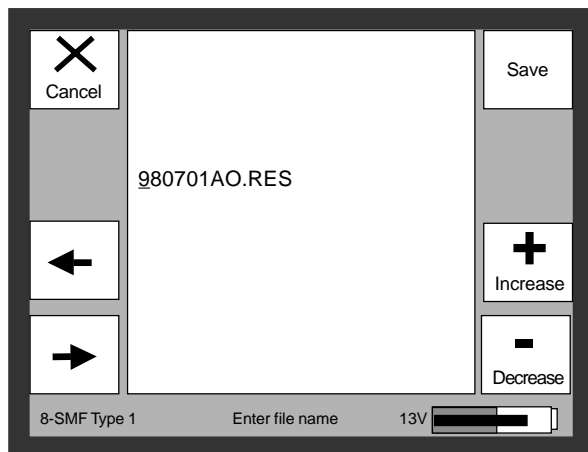

Fig. 80 - Monitor showing suggested file name

9. When the name is correct press:

SAVE

Note:

The splice result is now saved under the correct directory.

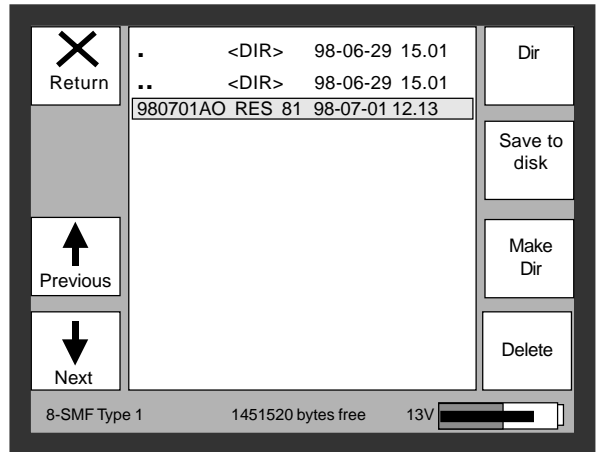

Fig. 81 - Monitor showing the saved splice result

Saving the splice result under a new directory

1. From the Disk utilities menu select the text "Splice results" and press:

RUN

2. Press:

MAKE DIR

3. A suggested directory name appears on the monitor. However, this can be changed if desired by moving the cursor (-) forwards or backwards with the help of the right and left arrows and then pressing:

INCREASE or DECREASE

4. When the directory name is correct press:

SAVE

Note:

The new directory is created on the disk and the contents of the disk is shown according to fig. 76.

5. Follow steps 4 to 9 as described under para. "Saving the splice result under an existing directory".

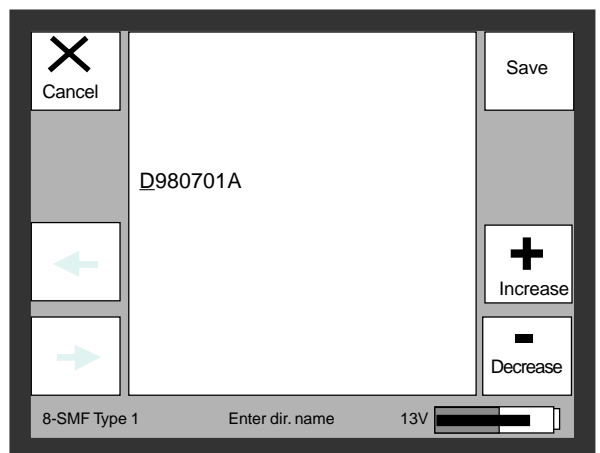

Fig. 82 - Monitor showing suggested directory name

Saving a splice result under the root directory

1. From the Disk utilities menu select the text "Splice results" and press:

RUN

2. It is not necessary to select or create a directory now, just press:

SAVE TO DISK

3. Select the result to be saved and press:

SAVE TO DISK

Note:

To save all splicing results press SAVE ALL TO DISK.

4. A suggested file name appears on the monitor and can be changed if necessary.

5. Press:

SAVE

Note:

The result is now saved on the disk (under the root directory)

Saving splice results between specific dates

1. From the Disk utilities menu select the text "Splice results" and press:

RUN

2. Press either:

DIR, SAVE TO DISK or MAKE DIR as described previously.

3. Press:

DATE

Note:

The date can be changed as necessary.

4. Press:

SAVE

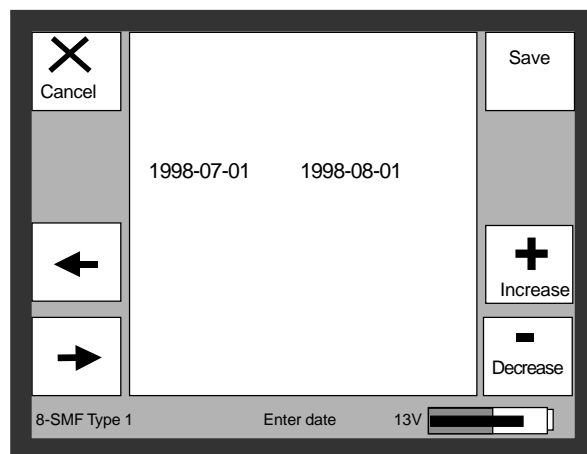

Fig. 83 - Monitor showing date format

Example of splice result file format

980629AM.RES										
Estimation values										
Ver 1										
1998-06-22	16:23	1	0.10	0.03	0.03	0.03	0.02	0.03	0.03	0.02
1998-06-22	16:09	1	0.04	0.04	0.04	0.04	0.04	0.03	0.03	0.04

The file is of an ASCII type and can be edited with a text editor. All the parameters are separated with tabs which makes it easy to read into, for example, Microsoft Excel.

Saving a splice program onto the disk

- From the Disk utilities menu select the text "Splice programs" and press:

RUN

- The monitor changes as illustrated in fig. 84. At this point the window is empty and the user can choose to save the splice program either:
 - under a directory already existing on the disk
 - under a new directory
 - directly onto the disk (under the root directory)

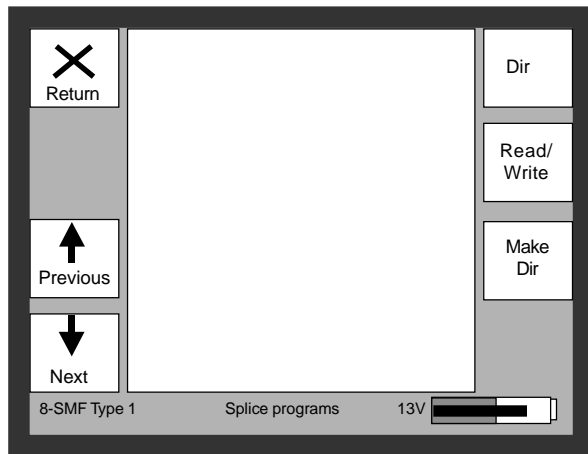

Fig. 84 - Monitor display after pressing RUN

- Press:

READ/WRITE

Note:

All the splicing programs appear on the monitor as in fig. 85.

- Mark the splicing program to be saved (1 to 50).

Note:

Observe that the icons EDIT NAME and READ FROM DISK appear on the monitor when you move down the program list to program 21.

- Give the splice program a new name if necessary by pressing:

EDIT NAME and SAVE

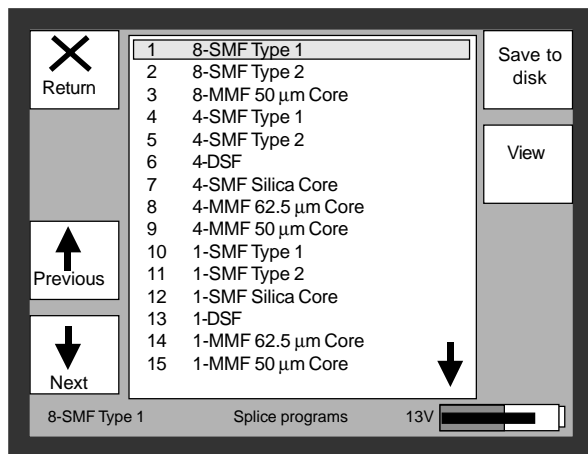

Fig. 85 - Splicing programs listed on the monitor

- Save the program onto the disk by pressing:

SAVE TO DISK

Note:

The monitor shows the Enter file name format and unless you change the name, the selected program will be saved under the name shown on the monitor.

- Save the program onto the disk by pressing:

SAVE

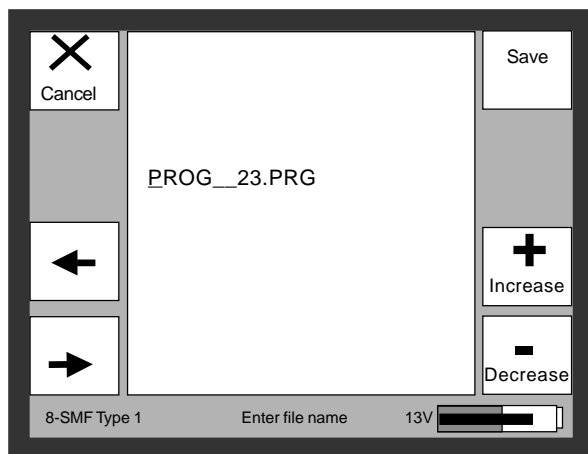

Fig. 86 - Enter file name format displayed on monitor

Reading a splice program from the disk into the splicer

1. From the Disk utilities menu select the text "Splice programs" and press:

RUN

2. The monitor changes as illustrated in fig. 87. At this point the window is empty.

3. List the contents of the disk on the monitor by pressing:

DIR

4. Select the splicing program (PRG) to be read over onto the splicer.

5. List all the splicing programs by pressing:

READ/WRITE

6. Move down the list until you reach the program number (21 to 50) where the program on the disk is to be stored.

Note:

Observe that the icons EDIT NAME and READ FROM DISK appear on the monitor when you move down the program list to program 21.

7. Press:

READ FROM DISK

Note:

The program has now been read over from the disk to the splicer. Any program name previously stored will be overwritten by the new one but not the program number.

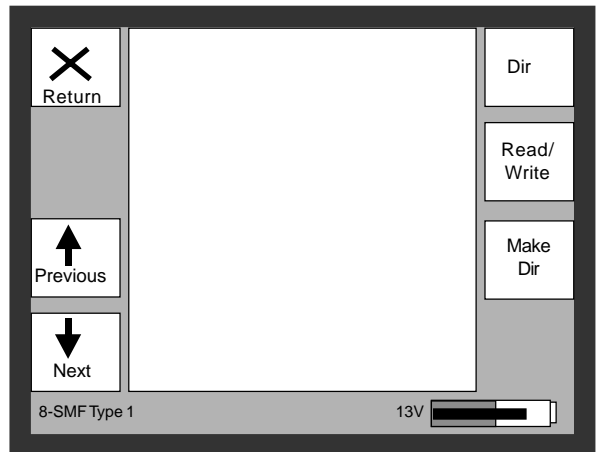

Fig. 87 - Monitor display after pressing RUN

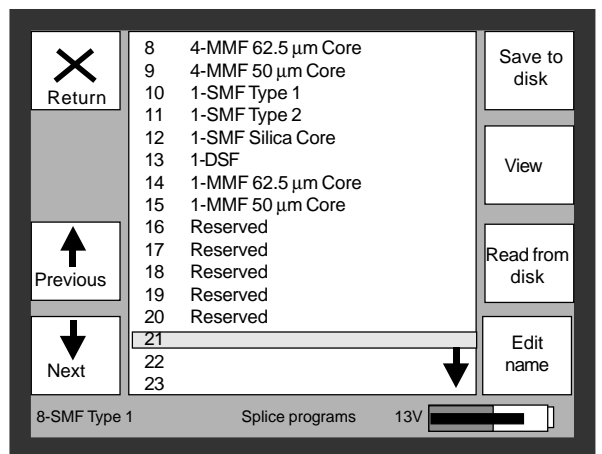

Fig. 88 - Program 21 selected where the splice program from the disk will be stored

Example of a saved splice program format

PROG __01.PRG

Program name=	”8-SMF Type 1”
Program number=	1
Prefuse distance=	45.00 μm
Prefuse current=	20.00 mA
Prefuse time=	0.40 s
Gap=	25.00 μm
Overlap distance=	44.00 μm
Overlap current=	19.60 mA
Overlap time=	1.20 s
Fusion current 1=	20.40 mA
Fusion time 1=	7.00 s
Pull=	40.00 μm
Fusion current 2=	25.60 mA
Fusion time 2=	3.00 s
Relax current=	15.00 mA
Relax time=	0.00 s
Camera amplification 1=	7.00 dB
Camera amplification 2=	-9.00 dB
Dirt size limit=	10.00 μm
Cleave angle limit=	3.00 $^{\circ}$
Cleave length diff. limit=	15.00 μm
Cladding offset limit=	4.00 μm
Left mode field diameter=	9.80 μm
Right mode field diameter=	9.80 μm
Estimation method=	Core
Fiber type=	SMF

Error messages

Below is a list of error messages that can appear on the monitor during the procedures mentioned previously.

Error Code	Error
2	File not found or path to file not found
9	Invalid file descriptor
17	Exclusive access requested but file already exists
13	Attempt to open a read only file or a special directory
22	Seek to negative file pointer attempted
24	No file descriptors available (too many files open)
28	Write failed. Presumably because of no space
30	Open failed due to sharing
31	Delete failed
32	Make directory failed
33	Read failed
100	Disk missing
0	Disk missing or empty
	"Error in file" - Syntax fail in splice program file
	"Error at line..."
	"Min/max error" - Max. or min. values fail in splice program file
	"Error in file" - Key word fail in splice program file
	"Error at line..."
	File too big

Adjust arc position

This utility checks whether or not the arc is positioned exactly at the fibre alignment line during splicing, and adjusts the position of the arc if necessary. If the arc is not positioned at the middle of the splice line then the loss is greatly increased.

Use the Adjust arc position utility after:

- changing or cleaning the electrodes
- changing the splice program
- operating in a new environment

Note:

The deviation from the default position (in pixels) is shown at the top of the image (see fig. 89). A positive value means that the arc has been moved to the left, a negative value means that it has been moved to the right.

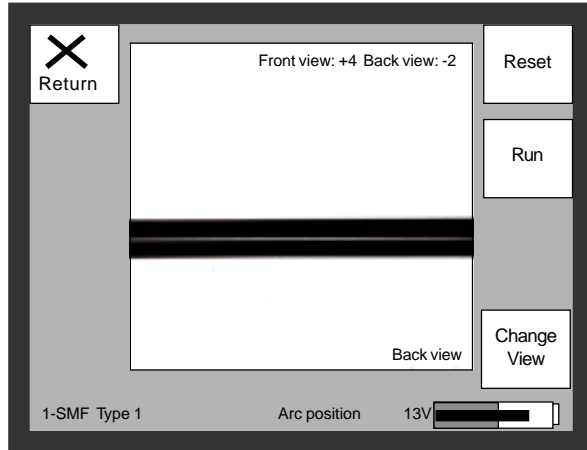

Fig. 89 - Monitor after selecting "Adjust arc position"

How to adjust the arc position

1. Put a long piece(s) of stripped and cleaned fibre(s) into the splicer.

Note:

Do not cleave the fibre(s).

2. Ensure the correct splicing program for this fibre is selected.

3. From the Utilities menu select "Adjust arc position". The monitor changes as shown in fig. 89.

4. Press:

RUN

5. The arc is lit and the splicer automatically checks and adjusts the position of the arc on the splice line by image processing the hot fibres.

Note:

Pressing RESET restores the default position of the arc (i.e. zero) (fig. 91)

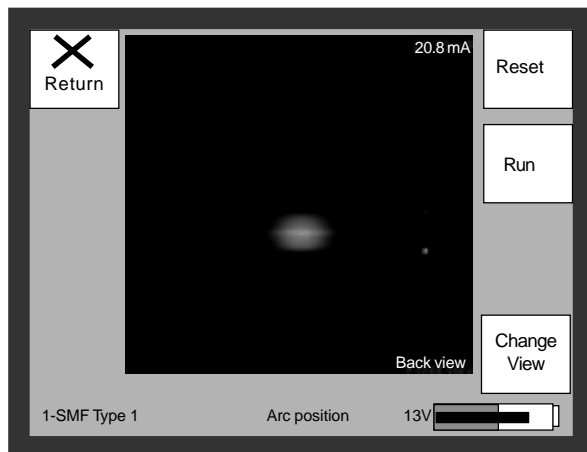

Fig. 90 - Monitor after pressing RUN

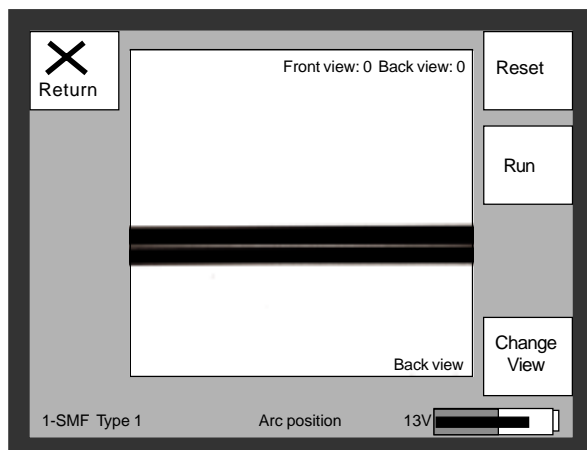

Fig. 91- Monitor after pressing RESET

Calibrate motors

This utility moves both the stepper motors backwards to their end positions and then forwards to their start position.

After the motors have been calibrated the fibres are positioned symmetrically around the splice line.

Note:

If the power is disconnected before the splicer is switched off, then the motors are automatically calibrated after start-up. The position of the motors and fibres is automatically saved each time the splicer is switched off.

Chapter 6 - Maintenance

Maintenance procedures

Only a few simple maintenance procedures are needed to ensure the efficient performance of the RSU 4 splicer. These procedures described in this chapter are as listed. However, please note that this is not a fully detailed RSU service instruction.

- *how to clean the V-grooves and fibre holder clamps*
- *how to clean the fibre holders*
- *how to change the electrodes*
- *how to clean the optical parts*

General rules

1. Petroleum products are prohibited for use as a cleaning agent.
2. Never use any type of hard tool for cleaning, otherwise sensitive surfaces can be damaged.
3. Never use any type of solvent other than pure ethanol or propanol for cleaning.

Important!!

Any fault messages generated from service mode etc. should be referred to authorised service personnel.

How to clean V-grooves and fibre holder clamps

1. Open the fibre holder clamps.
2. Using the special brush provided, clean the V-grooves, starting from the inside edge and moving outwards (fig. 91).

Note:

If the V-grooves are very dirty, use a prepared fibre to scratch them clean.

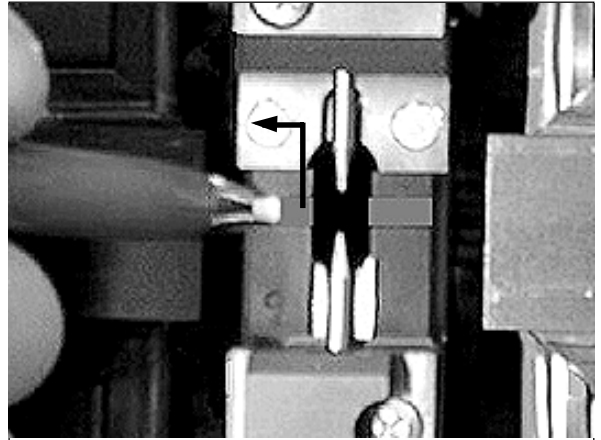

Fig. 91 - Cleaning the V-grooves

3. Clean fibre holder clamps and V-grooves with a cotton swab dipped in pure alcohol.
4. Check that no cotton threads remain after cleaning.

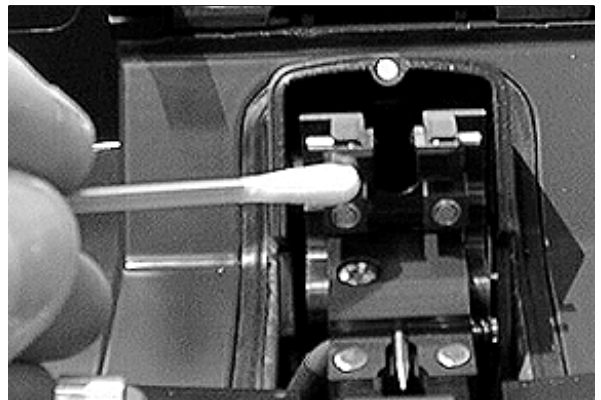

Fig.92 - Cleaning fibre holder clamps with cotton swab

How to clean fibre holders

1. Open the fibre holder lids.
2. Brush the fibre holders.
3. Clean again with a cotton swab dipped in pure propanol or ethanol.
4. Control the mechanism for closing the fibre holders, especially the magnetic function.

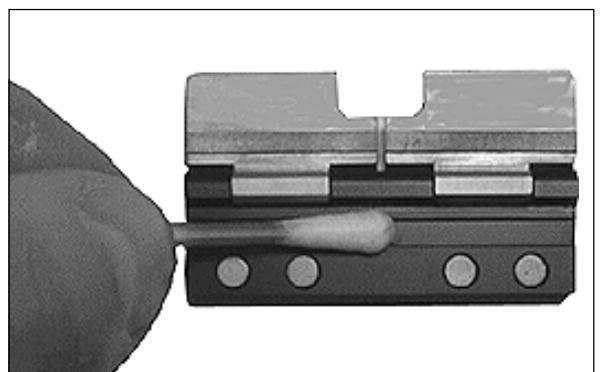

Fig. 93 - Cleaning the fibre holders

How to change the electrodes

Electrodes are normally changed after every 1000 splices depending upon the type of fibre and splice program used.

1. Loosen the electrode lock's fixing screws and remove them (figs. 94a and 94b).

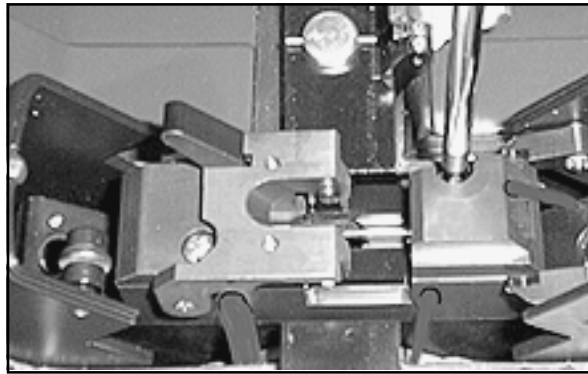

Fig. 94a - Loosening the front electrode lock fixing screw

2. Take hold of the electrodes with the special tweezers and remove them.
Note:
The tips of the electrodes are very fragile so do not touch them with anything, not even your hands.

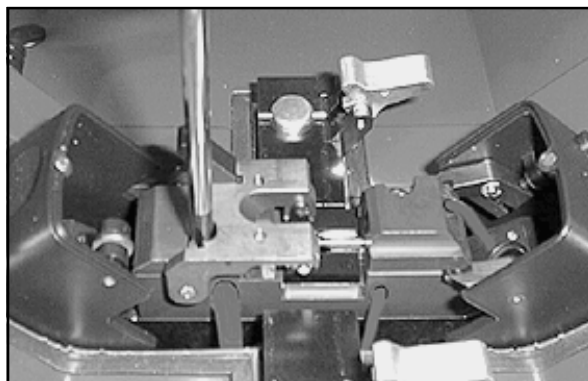

Fig. 94b - Loosening the back electrode lock fixing screw

3. Mount the new electrodes correctly in their holders (figs. 95a and 95b)

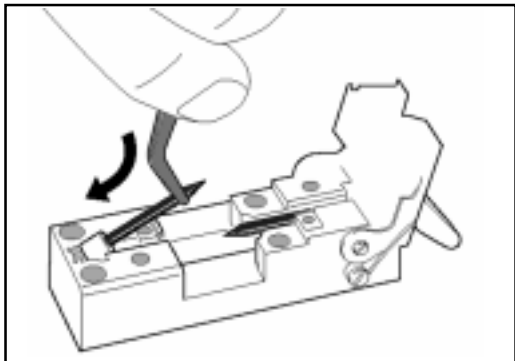

Fig. 95a - Inserting the new electrode at the correct angle

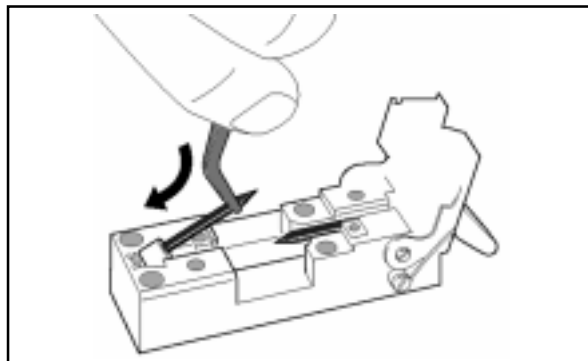

Fig. 95b - Positioning the new electrodes in the housing

4. Tighten the electrode lock's fixing screws.
5. Run the electrode cleaning program (see Chapter 5 "The Utilities menu") and check that the arc is stable.
Note:
When replacing the electrodes, always reset the splice counter in the basic user parameters (see Chapter 4 "The set up menu")
6. Run the utility "Adjust arc position" (see Chapter 5 "Utilities menu").

How to clean the optical parts

The optical parts should normally be cleaned after approximately 100 to 200 splices depending upon the fibre type and splice program used.

1. Clean the mirrors and LED protective windows with a cotton swab dipped in pure propanol or ethanol.

Note:

The best way to ensure clean surfaces is to move the cotton swab in circular movements from the middle and outwards.

2. Remove the electrodes and clean the camera lenses with a cotton swab.

Note:

The cotton swab should be slightly dampened and not completely wet through.

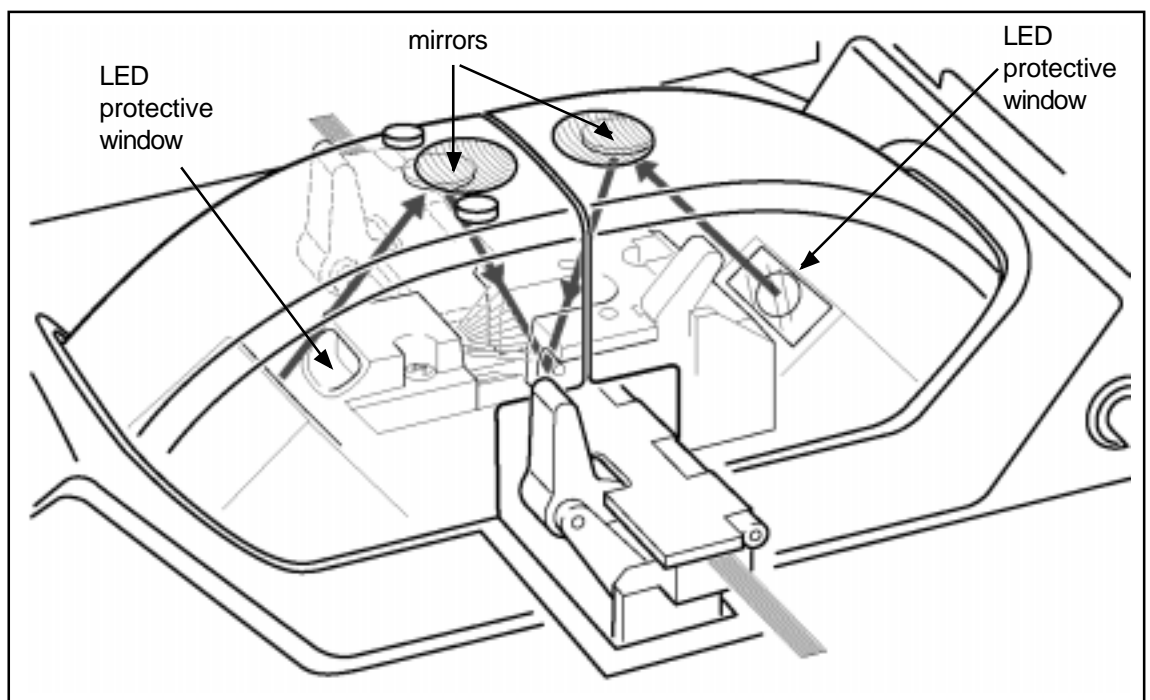

Fig. 96 - Schematic view of the RSU 4 showing positioning of the mirrors and LEDs

Appendix A - Troubleshooting

Problem	Action	Chapter
Splicer does not start	<ol style="list-style-type: none"> 1. Check the power connection. 2. Press the On/Off button and keep it pressed until the green lamp on top left of the monitor lights. 	1
No power to the stripper and ultrasonic cleaner	<ol style="list-style-type: none"> 1. Check the power connection from the splicer to the stripper/ultrasonic cleaner. 	1
Cladding Offset (i.e. radial misalignment) between fibres is too large	<ol style="list-style-type: none"> 1. Check the fibre clamps. 2. Try to adjust the radial alignment of the fibre by pressing the fibre adjustment buttons on top of the safety shield. 3. Clean the V-grooves. 4. Clean the fibres. 5. Change the Cladding Offset Limit in the current splice program if your splice loss requirement allows. 	2 6 2 4
Cleave angle too big	<ol style="list-style-type: none"> 1. Ensure the cleaver is clean. 2. Rotate the cleaver's diamond cutter one step according to the cleaver's documentation. 3. Change the Cleave Angle Limit in the current splice program if your splice loss requirement allows. 	4
No fibre movement when <i>Splice</i> button is pressed	<ol style="list-style-type: none"> 1. Ensure there is no dust on the fibres. 2. Go to <i>Utilities, Manual Splice</i>. Run stepper motors manually and check if they move. 3. Interchange right and left fibre holders and repeat the fibre preparation procedure if the fibres can be moved manually. 	2 5 2
Cold image too dark	<ol style="list-style-type: none"> 1. Clean the illumination mirrors in the safety shield. 2. Clean the LED protection windows. 3. Clean the optical filters at front of the cameras. 	6 6 6
Hot image too dark	<ol style="list-style-type: none"> 1. Clean the optical filters at the front of the cameras. 2. Check if the correct splice program is chosen. 3. Increase fusion currents in present splice program or run the <i>Auto current adjustment</i> utility. 	6 4 4,5
Hot image too bright	<ol style="list-style-type: none"> 1. Check if the correct splice program is chosen. 2. Decrease arc currents in present splice program, or run the <i>Auto current adjustment</i> utility. 	4 4,5
Noisy and unstable arc	<ol style="list-style-type: none"> 1. Brush electrodes and run <i>Electrode Cleaning</i> in <i>Utilities</i>. 2. Replace electrodes with new ones if arc is still not stable. 	5 6
High loss splices	<ol style="list-style-type: none"> 1. Clean V-grooves. 2. Clean the fibres. 3. Run <i>Adjust arc position</i>. 4. Run <i>Auto current adjustment</i> utility. 	6 2 5 5

Appendix B - Technical data

Fibres:	<ul style="list-style-type: none"> - Single-mode, multimode and dispersion-shifted fibre. - Single fibre 125/250 µm and 125/900 µm. - Ribbon fibre with up to 4 fibres.
Typical splice losses:	0.04 dB for identical SM 4 fibre ribbon.
Fibre positioning:	Fixed V-grooves for radial alignment. High precision stepper motors for axial alignment.
Power supply:	From power supply 100-240 V AC, 50-60 Hz. from attachable battery or directly from car battery 12 V DC.
Operation environment:	0-45° C, humidity max 98% RH non-condensing.
Storage environment:	-20 - +60°C, 0-98% RH (non-condensing).
Monitor/fibre magnification	6.5" TFT colour display/ 75 x magnification.
Video output:	VGA 15-pin.
Power output:	12V DC, DIN 6-pin, 2 outputs.
Size:	223x346x165 mm (8.8" x 13.6" x 6.5"), (WxDxH).
Weight:	5.3 kg (11.7 lbs).
Carrying case:	Sturdy cabin-sized case with extra space for the accessories.
Carrying case size:	532 x 411 x 220 mm (20.9" x 16.2" x 8.7"), (WxDxH in an upright position).

Appendix C - Proof testing (optional)

General

It is sometimes desirable to test the strength of the fibres after they have been spliced. To achieve this, a special tensile proof tester is available as an option and can be operated as described.

Preparing the fibre for proof testing

1. Move the spliced fibre into the heat oven and tensile proof tester (*see chapter 2 "How to protect the splice"*).

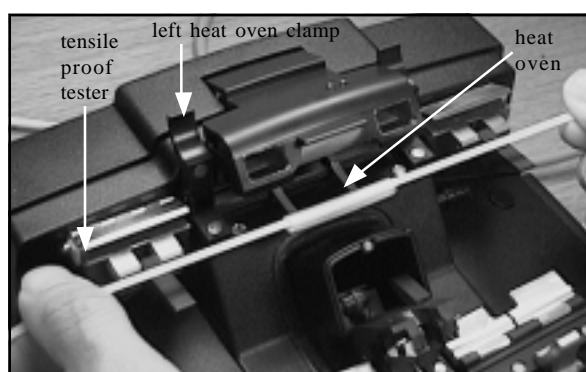

Fig. 1 - Moving the spliced fibre to the heat oven and tensile proof tester

2. When the fibre is placed into the left and right heat oven clamps, they automatically close.

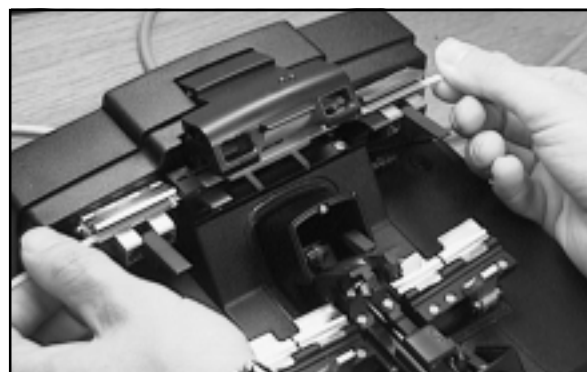

Fig. 2 - Placing the fibre into the heat oven clamps

3. Close the tensile proof tester's right and left clamps.

Note:

The fibre is now ready to be tensile tested.



Fig. 3 - Closing the proof tester's clamps

Changing the proof test program

1. From the Main menu, press:

SET UP and then PROGRAM

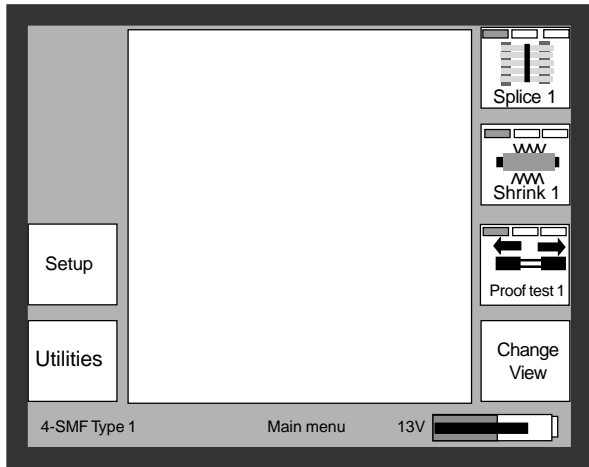

Fig. 4 - Main menu

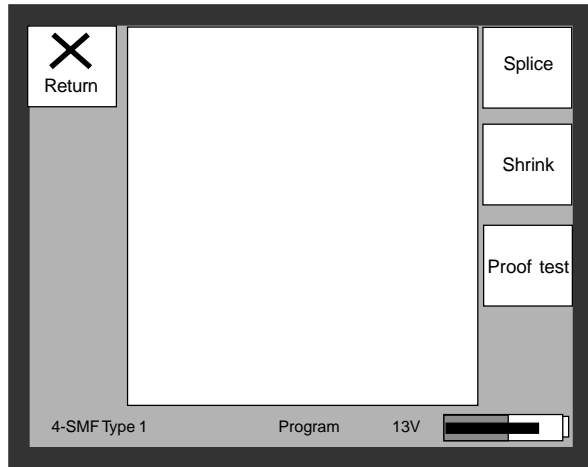

Fig. 5 - Monitor after pressing PROGRAM

2. Press PROOF TEST

Note:

The available proof test programs are displayed on the monitor (fig. 6)

3. Highlight the correct proof test program by pressing:

NEXT

4. Select the proof test program by pressing:

USE

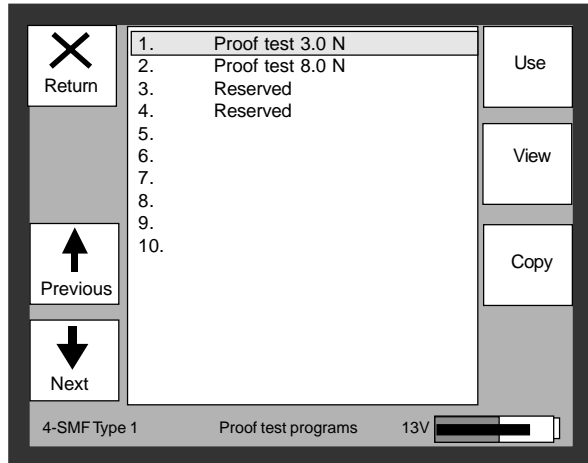

Fig. 6 - Monitor after pressing PROOF TEST

5. From the Main menu press:

PROOF TEST

Note:

The SPLICE/RESPLICE icons disappear from the monitor to prevent splicing and proof testing from occurring at the same time.

6. The proof test program starts and the monitor appears as shown in fig. 7.

Max Load = the maximum permissible load according to the proof test program used.

Load reached = the load reached so far

Time = the real time from start to end of the proof test program

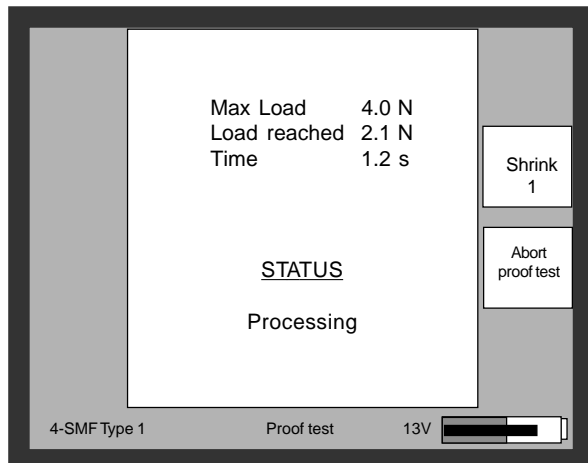

Fig. 7 - Monitor display after proof test program starts

7. The proof test program finishes and the monitor appears as shown in fig. 8.
8. Return to the Main menu by pressing:
RESET PROOF TEST

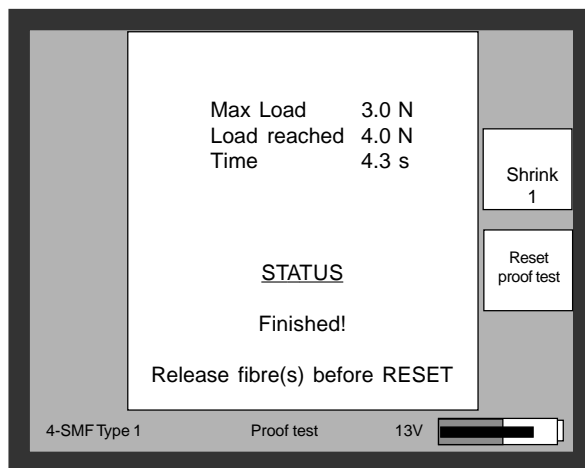

Fig. 8 - Monitor display when program finishes

Parameters

The parameters for the proof test program can be seen by pressing VIEW when the proof test programs are displayed on the monitor.

Change the parameters if necessary in the same way as for splicing or shrinking parameters (see chapter 4, para. "How to change parameters")

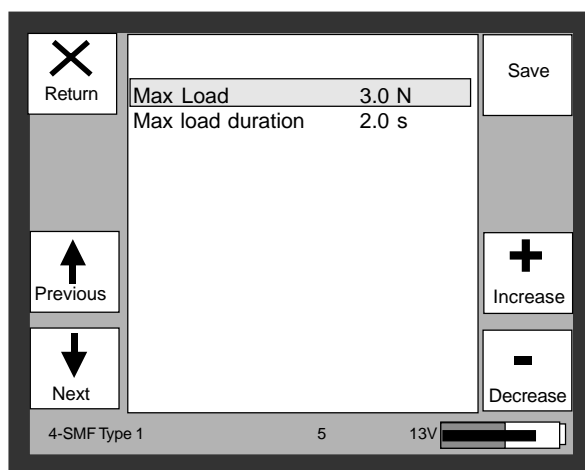

Fig. 9 - Monitor after pressing VIEW

Proof test parameters and limit values

No.	Parameter	Unit	Lower Limit	Upper Limit	Step
1	Max load	N	0.0	30	0.2
2	Max load duration	s	0.0	60	0.5

Table 1 - Proof test parameters and programs

List of Contents

	Page No.
Introduction	1
Scope and purpose of manual	1
The reader	1
Software	1
Introduction to the RSU 8	2
Applications	2
Chapter 1 - Installation	3
Safety and precautions	3
Operational safety precautions	3
Transport and storage precautions	3
Maintenance precautions	3
Installation upon delivery	4
Unpacking the splicer	4
Removing the cover	4
Unlocking the safety shield	4
RSU 8 splicer kit	5
Overview of external parts	6
Part description	7
Chapter 2 - Basic operation	8
How to start the splicer	8
How to prepare the fibres	10
How to strip the fibres	10
How to clean the fibres	11
How to cleave the fibres	12
How to position fibres correctly in the V-grooves	13
Examples of fibre problems	13
How to carry out the auto splicing process	14
Testing the strength of the spliced fibres (optional)	15
How to protect the splice	15
Reference notes	17
"Pause before fusion" setting - "ON"	17
"Pause before fusion" setting "OFF"	17
Examples of problems that can cause the splice process to halt before fusion	18
"Show all est. losses" setting "ON"	18
"Show all est. losses" setting "OFF"	18

Chapter 3 - Evaluating the splice	19
Images	19
General	19
Type of images	19
Displaying the stored images	20
Order of the stored images	20
How to see evaluated information from the stored images	21
Presplice (cold image)	21
Overlap (cold image)	21
Hot images 1, 2 and 3	21
Postsplice (cold image)	21
How to see check the fusion current	22
Reference notes	23
Examples and analysis of different problems detected when evaluating the hot images	23
 Chapter 4 - The Set up menu	 24
General	24
Options available	24
Program	25
Displaying programs on the monitor	25
Splicing programs	26
Pre-defined splicing programs	26
User-definable splicing programs	26
The nine main steps of splicing	27
Splicing parameters	28
Primary splicing parameters	29
Advanced splicing parameters	29
Shrinking programs	30
The three main steps of the shrinking sequence	30
Shrinking parameters	31
How to select and activate a program	32
How to copy a program	33
How to change parameters	34
How to edit a program name	35
Language	36
User	37
How to change basic splicer parameters	37
Service	37
Reference notes	38
Basic user parameters	38
 Chapter 5 - The Utilities menu	 39
General	39
Electrode cleaning	40

Auto current adjustment	41
Procedure	41
Reference notes	43
How the splicer automatically adjusts the Current Adjustment Value parameter	43
Images from last splice	44
Read sensors	44
Manual splicing	45
Splice results	47
Disk utilities	48
Saving a splice result onto a disk	49
Saving a splice result under an existing directory	49
Saving a splice result under a new directory	51
Saving a splice result under the root directory,	52
Saving splice results between specific dates	52
Example of splice result format	53
Saving a splice program onto the disk	54
Reading a splice program from the disk into the splicer	55
Example of splice program format	56
Error messages	57
Adjust arc position	58
How to adjust the arc position	58
Calibrate motors	59
Chapter 6 - Maintenance	60
Maintenance procedures	60
General rules	60
How to clean V-grooves and fibre holder clamps	61
How to clean fibre holders	61
How to change the electrodes	62
How to clean the optical parts	63
Quick reference guide for splicing	
Appendix A - Troubleshooting	
Appendix B - Technical data	
Appendix C - Proof testing (optional)	
Appendix D - Representatives	
Index	

Index

A

ABORT SPLICE, 17
Adjust arc position, 58
Adjusting the fibres, 17
Auto current adjustment, 41
Auto splicing process, 14
AUX1, 6
AUX2, 6

B

Bad cleave angle, 18
Battery
 connector, 6
 inlet, 7
 warning limit, 38
Brush, electrode, 5
Brush for V-grooves, 5

C

Calibrate motors, 59
Camera Amplification 1, 29
Camera Amplification 2, 29
Cameras, 19
Chinese, 36
Cladding Offset Limit, 17
Cladding offsets, 14, 17
Clamp, 12
 of tensile proof tester, 1(App C)
Cleaning process 11
Cleave Angle Limit 17, 27
 Length Difference Limit, 17,29
 length, uneven 18
Cleaver, 12
Close, 27
Close Time, 27
Coating, 10
Cooling, 30
Cooling process, 16
Core, 23
 eccentricity, 23
 offset, 23
Cover, removing 4
Critical Splice Area, 21, 23
Current Adjustment Value, 41, 42, 43

D

Date, 38
Decimal character, 38
Diamond blade, 12
Dirt Size Limit, 27
Disk Utilities, 48
Display contrast, 38
Dust on the fibres, 13

E

Electrode brush, 5
 cleaning program, 40
 tweezers, 5
Electrodes, cleaning, 9
 how to change, 62
Error messages, disk utilities, 57
Estimation, 27
 data, total, 21
 limit, 18
 Method, 27
 mode, off, 18
 mode, on, 18
 values, 18
Evaluating stored images, 21
External connections, 6
 outlets, 7
 parts, 6
 VGA display, 8

F

Fan off temperature, 31
Fibre adjustment buttons, 7, 17
 alignment, 17, 21, 27
 alignment line, 45, 58
 brightness value, 43
 clamp, raising, 13
 control, 27
 cores, 19
 holder clamps, raising, 13
 movement, 18
 problems, examples, 13
Fibre holder
 clamp, 7
 how to clean, 61
 lifting out of the cleaver, 12
 unit, 11
Fibres, broken, 13
 cleaning, 11
 cleaving, 12
 dust on, 13
 positioning in V-grooves, 13
 preparing, 10
 stripping, 10
 testing strength of, 1(App C)
Function buttons, 7
Fusion Current 1 value, 43
 Current 2 value, 43
 currents, 22, 41
 heat, correct, 22
 heat, too high, 22
 too low, 22

G

Geometry, 14

H

Heat oven, 7, 15, 30
 lid, 15, 16
Heat-shrink sleeve, 15
 centering, 15
Heat-shrinkable protection sleeve, 10
Hot images, 21
Hot spots, 23
Humidity, 3

I

Images, 19
 cold, 19
 displaying, 20
 from last splice, 41, 44
 hot, 19
 stored, evaluating, 21
 stored order of, 20
 types of, 19
Installation, 4

L

Lamp level, 38
Lamp signalling system, 30
Language, 36
Leaf, 29
LED protective windows, 63
Left Mode Field Diameter 27, 29
Light intensity profile, 22
Load reached, 2

M

Main Fuse 1, 27
 Fuse 2, 27
 Fuse Current 1, 27
 Fuse Current 2, 27
 Fuse Time 1, 27, 29
 Fuse Time 2, 27
Maintenance, 60
 general rules, 60
 procedures, 60
Manual splicing, 45
Max Load, 2
Max preheat time, 3, 31
Melting sequence 1, 30
Min. shown est. loss, 18, 38
Mirrors, cleaning, 63
Modified Chemical Vapour
 Deposition, 26

O

- Optical parts, how to clean, 63
- Outside Vapour Deposition, 26
- Oven lamp, 38
- Overlap, 27
 - cold image, 21
 - Current, 27
 - Distance, 27, 29
 - Time 27, 29

P

- Parameters
 - basic user, 38
 - how to change, 34
 - proof test, 3
- Pause before fusion, 38
 - setting - "Off", 17
 - setting - "On", 17
- Portable case, 5
- Postsplice (cold image), 21
- Power connection 6, 7
- Power save wait, 38
- Pre-heating, 30
- Precautions, 3
 - maintenance, 3
 - operational, 3
 - transport and storage, 3
- Prefuse Current, 27, 29
- Prefuse Distance, 27, 29
- Prefuse Time, 27, 29
- Prefusion, 27
- Presplice (cold image), 21
- "Process" LED, 11
- Program, 25
 - displaying, 25
 - how to copy, 33
 - how to edit name, 34
 - selecting, 32
- Programs, shrinking, 30
 - splicing about, 26
- Proof test program, changing, 2
 - parameters, 3
- Proof testing, 1
- Protecting the splice, 15
- Pull, 27
 - Distance, 27
 - Time, 27, 29

R

- Read sensors, 44
- Relax, 27
 - Current, 27
 - Time, 27
- Results, 47
- Ribbon clamps, 15
- Ribbon, moving to heat oven, 15
- Ribbons, putting into fibre holders, 10
- Right Mode Field Diameter, 29

S

- Safety, 3
 - shield, 7, 13
 - shield lock, 7, 13
 - shield, unlocking, 4
 - Service, 37
 - Set up menu, 24
 - Show all estimated losses, 18, 38
 - Shrinking process, 16
 - sequence, 30
 - sequence, schematic, 30
 - temperature, 31
 - time, 31
 - Silica glass optical fibers, 3
 - Sleeve, shrinking, 15
 - Sound, 38
 - Spare electrode set, 5
 - Splice
 - count, 38
 - line, 59
 - Splice program,
 - reading from disk to splicer, 55
 - saving onto disk, 54
 - Splice protecting, 15
 - Splice result,
 - saving onto a disk, 49
 - saving under new directory, 51
 - saving under an existing directory, 49
 - saving under root directory, 52
 - saving between specific dates, 52
 - Splicer,
 - connect to power supply, 8
 - kit, 5
 - reset, 14
 - settings, how to change, 37
 - starting, 8
 - turning on, 9
 - Splicing,
 - main steps, 27
 - problems, 23
 - process, schematic, 28
 - programs, pre-defined, 26
 - programs, user-definable, 26
 - Stripper, connecting, 8
- ## T
- Technical data, (App. B)
 - Thermal radiation, 19
 - Time, 2, 38
 - Tool set, 5
 - Total count, 38
 - Troubleshooting (App. A)
 - True Wave, 29
 - Turn off wait, 38
 - Tweezers, electrode, 5

U

- Ultrasonic cleaner, connecting, 9
- Ultrasonic cleaner, 11
- Unpacking the splicer, 4
- User, 37
- Utilities menu, 39

V

- V-grooves
 - brush, 5
 - cleaning, 9, 61
- Vapour-phase Axial Deposition, 26
- VIEW EXTRA, 29
- Views, alternating, 17

W

- White vertical line, 23

Y

- Yellow lamp, 16